



2008 FLT Police Models Service Manual Supplement

©2007 H-D.
ALL RIGHTS RESERVED
99483-08SP

Printed in the U.S.A.

VISIT THE HARLEY-DAVIDSON WEB SITE
<http://www.harley-davidson.com>

ABOUT THIS MANUAL

GENERAL

This Service Manual Supplement has been designed to be used with the current Service Manual and has been prepared with two purposes in mind. First, it will acquaint the user with the construction of the Harley-Davidson product and assist in the performance of basic maintenance and repair. Secondly, it will introduce to the professional Harley-Davidson Technician the latest field-tested and factory-approved major repair methods. We sincerely believe that this Service Manual Supplement will make your association with Harley-Davidson products more pleasant and profitable.

NOTE

This Service Manual Supplement provides information unique to this model motorcycle. Any information not presented in this supplement can be found in the appropriate Service Manual or Electrical Diagnostic Manual.

HOW TO USE YOUR SERVICE MANUAL SUPPLEMENT

Use the TABLE OF CONTENTS (which follows this FOREWORD) and the INDEX (at the back of this manual) to quickly locate subjects. Sections and topics in this manual are sequentially numbered for easy navigation.

NO.	CHAPTER
1	Maintenance
2	Chassis
3	Engine
4	Fuel System
5	Electric Starter
6	Drive
7	Transmission
8	Electrical
A	Appendix A Wiring
B	Appendix B Glossary

For example, a cross-reference shown as **2.1 SPECIFICATIONS** refers to chapter 2 CHASSIS, heading 2.1 SPECIFICATIONS.

If the subject you seek is not in this supplement, refer to the corresponding section in the appropriate Service Manual. Check the title page located in the front of each section to find the subject.

For quick and easy reference, all pages contain a section number followed by a page number. For example, page 3-5 refers to page 5 in section 3.

In figure legends, the number following the name of a part indicates the quantity necessary for one complete assembly.

PREPARATION FOR SERVICE

⚠ WARNING

Stop the engine when refueling or servicing the fuel system. Do not smoke or allow open flame or sparks near gasoline. Gasoline is extremely flammable and highly explosive, which could result in death or serious injury. (00002a)

Good preparation is very important for efficient service work. A clean work area at the start of each job will allow you to perform the repair as easily and quickly as possible, and will reduce the incidence of misplaced tools and parts. A motorcycle that is excessively dirty should be cleaned before work starts. Cleaning will occasionally uncover sources of trouble. Tools, instruments and any parts needed for the job should be gathered before work is started. Interrupting a job to locate tools or parts is a distraction and causes needless delay.

NOTES

- To avoid unnecessary disassembly, carefully read all relative service information before repair work is started.
- In figure legends, the number which follows the name of a part indicates the quantity necessary for one complete assembly.
- When servicing a vehicle equipped with the Harley-Davidson Smart Security System (H-DSSS), you must first disarm the security system. Either keep the fob in close proximity to the vehicle, or use Digital Technician to disable the security system while the vehicle is being serviced and re-enable the system after service is completed.

SERVICE BULLETINS

In addition to the information presented in this Service Manual Supplement and the appropriate Service Manual, Harley-Davidson Motor Company will periodically issue Service Bulletins to Harley-Davidson dealers. Service Bulletins cover interim engineering changes and supplementary information. Consult the Service Bulletins to keep your product knowledge current and complete.

USE GENUINE REPLACEMENT PARTS

⚠ WARNING

Do not use aftermarket parts and custom made front forks which can adversely affect performance and handling. Removing or altering factory installed parts can adversely affect performance and could result in death or serious injury. (00001a)

To ensure satisfactory and lasting repairs, carefully follow the Service Manual instructions and use only genuine Harley-Davidson replacement parts. Behind the emblem bearing the words GENUINE HARLEY-DAVIDSON stand more than 100 years of design, research, manufacturing, testing and inspecting experience. This is your assurance that the parts you are using will fit right, operate properly and last longer.

WARNINGS AND CAUTIONS

Statements in this service manual preceded by the following words are of special significance.

WARNING

WARNING indicates a potentially hazardous situation which, if not avoided, could result in death or serious injury. (00119a)

CAUTION

CAUTION indicates a potentially hazardous situation which, if not avoided, may result in minor or moderate injury. (00139a)

CAUTION

CAUTION used without the safety alert symbol indicates a potentially hazardous situation which, if not avoided, may result in property damage. (00140a)

NOTE

Refers to important information, and is placed in italic type. It is recommended that you take special notice of these items.

Proper service and repair is important for the safe, reliable operation of all mechanical products. The service procedures recommended and described in this service manual are effective methods for performing service operations.

WARNING

Always wear proper eye protection when using hammers, arbor or hydraulic presses, gear pullers, spring compressors, slide hammers and similar tools. Flying parts could result in death or serious injury. (00496b)

Some of these service operations require the use of tools specially designed for the purpose. These special tools should be used when and as recommended. It is important to note that some warnings against the use of specific service methods, which could damage the motorcycle or render it unsafe, are stated in this service manual. However, please remember that these warnings are not all-inclusive. Inadequate safety precautions could result in death or serious injury.

Since Harley-Davidson could not possibly know, evaluate or advise the service trade of all possible ways in which service might be performed, or of the possible hazardous consequences of each method, we have not undertaken any such broad evaluation. Accordingly, anyone who uses a service procedure or tool which is not recommended by Harley-Davidson must first thoroughly satisfy himself that neither his nor the operator's safety will be jeopardized as a result. Failure to do so could result in death or serious injury.

PRODUCT REFERENCES

WARNING

Read and follow warnings and directions on all products. Failure to follow warnings and directions can result in death or serious injury. (00470b)

When reference is made in this manual to a specific brand name product, tool or instrument, an equivalent product, tool or instrument may be substituted.

Kent-Moore Products

All tools mentioned in this manual with an "HD", "J" or "B" preface must be ordered through SPX Kent-Moore. For ordering information or product returns, warranty or otherwise, visit www.spx.com.

Loctite Sealing and Threadlocking Products

Some procedures in this manual call for the use of Loctite products. If you have any questions regarding Loctite product usage or retailer/wholesaler locations, please contact Loctite Corp. at www.loctite.com.

PRODUCT REGISTERED MARKS

Allen, Amp Multilock, Bluetooth, Brembo, Delphi, Deutsch, Dunlop, Dynojet, Fluke, G.E. Versilube, Gunk, Hydroseal, Hylomar, Kevlar, Lexan, Loctite, Lubriplate, Keps, K&N, Magnaflux, Marson Thread-Setter Tool Kit, MAXI fuse, Molex, MPZ, Multilock, Novus, Packard, Pirelli, Permatex, Philips, PJ1, Pozidriv, Robinair, S100, Sems, Snap-on, Teflon, Threadlocker, Torca, Torco, TORX, Tufoil, Tyco, Ultratorch, Velcro, X-Acto, and XM Satellite Radio are among the trademarks of their respective owners.

H-D MICHIGAN, INC. TRADEMARK INFORMATION

Harley, Harley-Davidson, H-D, Bar & Shield, Digital Tech, Digital Technician, Destroyer, Deuce, Dyna, Electra Glide, Evolution, Fat Boy, Glaze, Gloss, H-D, H-Dnet.com, HD, Harley, Heritage Softail, Heritage Springer, Low Rider, Night Rod, Night Train, Profile, Revolution, Road Glide, Road King, Rocker, Softail, Sportster, Sun Ray, Sunwash, Tech Link, Twin Cam 88, Twin Cam 88B, Twin Cam 96, Twin Cam 96B, Twin Cam 103, Twin Cam 103B, Twin Cam 110, Twin Cam 110B, Tour-Pak, Screamin' Eagle, Softail, Super Guide, Super Premium, SYN3, Ultra Glide, V-Rod, VRSC, Wide Glide, and Harley-Davidson Genuine Motor Parts and Genuine Motor Accessories are among the trademarks of H-D Michigan, Inc.

CONTENTS

All photographs, illustrations and procedures may not necessarily depict the most current model or component, but are based on the latest production information available at the time of publication.

Since product improvement is our continual goal, Harley-Davidson reserves the right to change specifications, equipment or designs at any time without notice and without incurring obligation.

MAINTENANCE

1.1 SCHEDULED MAINTENANCE

General.....1-1

CHASSIS

2.1 SPECIFICATIONS: CHASSIS

General.....2-1

2.2 VEHICLE IDENTIFICATION NUMBER (V.I.N.)

General.....2-2

2.3 TIRES

General.....2-3

2.4 SEAT

General.....2-4

Seat Removal.....2-6

Seat Installation.....2-6

Air Spring Replacement.....2-6

Removal.....2-6

Installation.....2-6

Seat Bracket Mount Replacement.....2-7

Removal.....2-7

Installation.....2-7

2.5 AIR SEAT RESERVOIR

Removal.....2-8

Installation.....2-9

2.6 SADDLEBAGS

Lockset.....2-11

Removal.....2-11

Installation.....2-11

Lockset Catch.....2-11

Removal.....2-11

Installation.....2-11

Hinges.....2-11

Removal.....2-11

Installation.....2-12

Tether.....2-12

Removal.....2-12

Installation.....2-12

Tether Brackets.....2-12

Removal.....2-12

Installation.....2-12

Knob and Spring Latch.....2-12

Removal.....2-12

Installation.....2-13

Spring Latch Bracket.....2-13

Removal.....2-13

Installation.....2-13

2.7 TACHOMETER BRACKET: FLHP/E

Removal.....2-14

Installation.....2-15

ENGINE

3.1 SPECIFICATIONS: ENGINE

General.....3-1

Manufacturing Tolerances.....3-1

3.2 SERVICE WEAR LIMITS

General.....3-2

3.3 OIL COOLER

Operation.....3-3

Removal.....3-3

Cleaning and Inspection.....3-4

Installation.....3-4

Oil Cooler Adapter and Thermostat Replacement.....3-4

Removal.....3-4

Installation.....3-4

FUEL SYSTEM

4.1 FUEL SYSTEM

No Unique Content.....4-1

ELECTRIC STARTER

5.1 ELECTRIC STARTER

No Unique Content.....5-1

DRIVE

6.1 DRIVE

No Unique Content.....6-1

TRANSMISSION

7.1 TRANSMISSION

No Unique Content.....7-1

ELECTRICAL

8.1 BULB CHART

General.....8-1

8.2 SYSTEM FUSES AND RELAYS

System Fuses.....8-3

Removal.....8-3

Installation.....8-4

8.3 REAR MARKER LIGHTS

Marker Lights Replacement.....8-5

Removal.....8-5

Installation.....8-5

8.4 HANDLEBAR SWITCHES

Horn and Siren Yelp Switch.....8-6

Removal.....8-6

Installation.....8-6

Clutch Interlock Switch.....8-7

Removal.....8-7

Installation.....8-7

Pursuit and Auxiliary Switch.....8-8

Removal.....8-8

Installation.....8-8

8.5 AUTOMATIC COMPRESSION RELEASE

General.....8-10

Removal.....8-10

TABLE OF CONTENTS

Installation.....	8-10
Compression Test.....	8-11
Diagnostics.....	8-12
Diagnostic Tips.....	8-12
Diagnostic Notes.....	8-12

APPENDIX A WIRING

A.1 CONNECTORS

Connectors.....	A-1
-----------------	-----

A.2 INDEX TO WIRING DIAGRAMS

Wiring Diagram Information.....	A-7
Wire Color Codes.....	A-7
Wiring Diagram Symbols.....	A-7

Wiring Diagrams.....	A-8
----------------------	-----

APPENDIX B GLOSSARY

B.1 GLOSSARY

Acronyms and Abbreviations.....	B-1
---------------------------------	-----

REFERENCE MATERIAL

TOOLS.....	I
-------------------	----------

TORQUE VALUES.....	III
---------------------------	------------

INDEX.....	V
-------------------	----------

SUBJECT

PAGE NO.

1.1 SCHEDULED MAINTENANCE.....1-1

NOTES

SCHEDULED MAINTENANCE

1.1

GENERAL

The table below lists the maintenance requirements for police motorcycles. If you are familiar with the procedures, refer to the table for the recommended service interval. If necessary, refer to the quick reference table ([Table 1-2](#)) for the required

specifications. If more detailed information is needed, turn to the Touring Models Service Manual for step-by-step instructions.

Various lubricants, sealants and greases are recommended in certain service operations. Refer to [Table 1-3](#) for the appropriate part numbers for these items.

Table 1-1. Regular Service Intervals: 2008 Touring Models

ITEM SERVICED	PROCEDURE	1000 MI. 1600 KM	5000 MI. 8000 KM	10,000 MI. 16,000 KM	15,000 MI. 24,000 KM	20,000 MI. 32,000 KM	25,000 MI. 40,000 KM	NOTES
Engine oil and filter	Replace	X	X	X	X	X	X	
Oil lines and brake system	Inspect for leaks	X	X	X	X	X	X	1
Air cleaner	Inspect, service as required	X	X	X	X	X	X	
Tires	Check pressure, inspect tread	X	X	X	X	X	X	
Wheel spokes	Check tightness	X	X			X		1
Primary chaincase lubricant	Replace	X		X		X		
Transmission lubricant	Replace	X				X		
Clutch	Check adjustment	X	X	X	X	X	X	1
Drive belt and compensator sprocket	Inspect, adjust belt	X	X	X	X	X	X	1
Compensator sprocket isolators	Inspect for wear							5
Brake and clutch controls	Check, adjust and lubricate	X	X	X	X	X	X	1
Jiffy stand	Inspect and lubricate	X	X	X	X	X	X	1
Fuel lines and fittings	Inspect for leaks	X	X	X	X	X	X	1
Fuel tank filter	Replace						X	1
Brake fluid	Check levels and condition	X	X	X	X	X	X	4
Brake pads and discs	Inspect for wear	X	X	X	X	X	X	
Spark plugs	Inspect Replace	X	X	X	X		X	
Electrical equipment and switches	Check operation	X	X	X	X	X	X	
Front fork oil	Replace							1, 2
Steering head bearings	Lubricate Adjust	X		X		X		2 1
Air suspension	Check pressure, operation and leakage	X	X	X	X	X	X	1
Windshield bushings (if applicable)	Inspect			X		X		1
Fuel door, Tour-Pak, saddlebags	Lubricate hinges and latches	X	X	X	X	X	X	
Critical fasteners	Check tightness	X		X		X		1
Engine mounts and stabilizers	Inspect, check tightness			X		X		1
Battery	Check battery and clean connections							3
Exhaust system	Inspect for leaks, cracks, and loose or missing fasteners or heat shields	X	X	X	X	X	X	3
Road test	Verify component and system functions	X	X	X	X	X	X	
NOTES:	1. Should be performed by an authorized Harley-Davidson dealer, unless you have the proper tools, service data and are mechanically qualified. 2. Disassemble, lubricate and inspect every 50,000 miles (80,000 kilometers). 3. Perform annually. 4. Change D.O.T. 4 and flush brake system every two years. 5. Perform at each rear tire change.							

Table 1-2. Quick Reference Maintenance Chart: 2008 Police Models

ITEM SERVICED	SPECIFICATION	DATA
Engine oil and filter	Drain plug torque	14-21 ft-lbs (19.0-28.5 Nm)
	Oil capacity	4 qt. (3.8 L)
	Filter	Hand tighten 1/2-3/4 turn after gasket contact
	Chrome filter part number	63798-99A
	Black filter part number	63731-99A
Primary chain lubricant	Lubricant type and capacity	FORMULA+ TRANSMISSION AND PRIMARY CHAIN LUBRICATION (Part No. 99851-05) Wet: 38 oz. (1124 ml) Dry: 45 oz. (1331 ml)
	Primary chaincase drain plug torque	14-21 ft-lbs (19.0-28.5 Nm)
Clutch adjustment	Adjuster screw free play	1/2-1 turn
	Adjuster screw locknut torque	72-120 in-lbs (8.1-13.6 Nm)
	Free play at hand lever	1/16-1/8 in. (1.6-3.2 mm)
	Clutch inspection cover torque	84-108 in-lbs (9.5-12.2 Nm)
Transmission lubricant	Lubricant level	Dipstick at FULL with motorcycle on jiffy stand and filler plug resting on threads.
	Lubricant type and capacity	FORMULA+ TRANSMISSION AND PRIMARY CHAIN LUBRICATION (Part No. 99851-05) 32 oz (0.95 liters)
	Transmission drain plug torque	14-21 ft-lbs (19.0-28.5 Nm)
	Transmission filler plug/dipstick torque	25-75 in-lbs (2.8-8.5 Nm)
Tire pressure and wear	Pressure: solo rider	Front: 36 psi (248 kPa) Rear: 36-40 psi (248-276 kPa)
	Wear	Replace if less than 1/32 in. (0.8 mm) of tread pattern
Wheel spokes	Spoke nipple torque	55 in-lbs (6.2 Nm) minimum
Brake fluid level	D.O.T. 4 hydraulic brake fluid part number	99953-99A (12 oz.)
	Fluid level (from top of master cylinder reservoir)	Front: 0.20 in. (5.0 mm) Rear: 0.26 in. (6.5 mm)
	Master cylinder reservoir cover screw torque	Front: 7-10 in-lbs (0.8-1.1 Nm) Rear: 12-15 in-lbs (1.4-1.7 Nm)
Brake pads and discs	Minimum brake pad thickness	0.016 in. (0.4 mm)
	Brake caliper pad pin torque	75-102 in-lbs (8.5-11.5 Nm)
	Minimum brake disc thickness	Front: 0.18 in. (4.5 mm) Rear: 0.25 in. (6.3 mm)
	Maximum brake disc lateral runout (warpage)	0.008 in. (0.2 mm)
Drive belt deflection	Upward force applied at midpoint of bottom belt strand	10 lb. (4.5 kg)
	FLHTP	3/8-7/16 in. (9.5-11.1 mm)
	FLHP/FLHPE	1/4-5/16 in. (6.4-7.9 mm)
Air cleaner	Air cleaner cover bracket screw torque	40-60 in-lbs (4.5-6.8 Nm)
	Air cleaner cover screw torque	36-60 in-lbs (4.1-6.8 Nm)
	Air cleaner cover screw Threadlocker	LOCTITE MEDIUM STRENGTH THREADLOCKER 243 (BLUE) Part No. 99642-97 (6 ml)
Clutch cable	Lubricant part number	LUBIT-8 SUPER OIL, Part No. 94968-85TV (1/4 fl. oz.)
	Handlebar switch housing screw torque	35-45 in-lbs (4.0-5.1 Nm)

Table 1-2. Quick Reference Maintenance Chart: 2008 Police Models

ITEM SERVICED	SPECIFICATION	DATA
Spark plugs	Type	HD-6R12
	Gap	0.038-0.043 in. (0.97-1.09 mm)
	Torque	12-18 ft-lbs (16.3-24.4 Nm)
Front fork oil	Amount	See FRONT FORK in the Touring Service Manual.
	Type and part number	HYDRAULIC FORK OIL (TYPE E) Part No. 99884-80 (16 oz.)
Battery	Terminal bolt torque	60-96 in-lbs (6.8-10.9 Nm)
	Top caddy clamp screw torque	15-20 ft-lbs (20-27 Nm)

Table 1-3. Lubricants, Greases, Sealants

ITEM	PART NUMBER	PACKAGE
Anti-Seize Lubricant	98960-97	1 oz squeeze tube
CCI #20 Brake Grease	42830-05 (included in master cylinder rebuild kit)	squeeze packet
D.O.T. 4 Brake Fluid	99953-99A	12 oz. bottle
Electrical Contact Lubricant	99861-02	1 oz squeeze tube
Genuine Harley-Davidson Formula+ Transmission and Primary Chaincase Lubricant	99851-05	1 qt bottle
G40M Brake Grease	42820-04	squeeze packet
Gray High Performance Sealant	99650-02	1.9 oz squeeze tube
HYLOMAR Gasket and Thread Sealant	99653-85	3.5 oz tube
Loctite Pipe Sealant With Teflon 565	99818-97	6 ml squeeze tube
Loctite Prism Primer (770)		
Loctite Prism Superbonder (411)		
Loctite Superbonder 420 Adhesive		
Loctite Threadlocker 243 (blue)	99642-97	6 ml squeeze tube
Loctite Threadlocker 262 (red)	94759-99	6 ml squeeze tube
Loctite Threadlocker 272	98618-03	10 ml bottle
Special Purpose Grease	99857-97	14 oz. cartridge
Super Oil	94968-85TV	1/4 fl. oz
Type "E" Hydraulic Fork Oil	99884-80	16 oz bottle

NOTES

SUBJECT	PAGE NO.
2.1 SPECIFICATIONS: CHASSIS.....	2-1
2.2 VEHICLE IDENTIFICATION NUMBER (V.I.N.).....	2-2
2.3 TIRES.....	2-3
2.4 SEAT.....	2-4
2.5 AIR SEAT RESERVOIR.....	2-8
2.6 SADDLEBAGS.....	2-11
2.7 TACHOMETER BRACKET: FLHP/E.....	2-14

NOTES

GENERAL

Table 2-1. Capacities: 2008 Police Models

ITEM	U.S.	LITERS
Fuel tank (total)	6.0 gal	22.7
Low fuel warning lamp on	1.0 gal	3.8
Oil tank with filter	4.0 U.S. qt.	3.8
Transmission (approximate)	32.0 fl. oz.	0.95
Primary chaincase (drained)	38.0 fl. oz.	1.12
Primary chaincase (cover removed)	45.0 fl. oz.	1.33

Table 2-2. Dimensions: 2008 Police Models

ITEM	FLHTP		FLHP	
	IN.	MM	IN.	MM
Wheel base	63.5	1612.9	63.5	1612.9
Overall length	93.7	2380	93.7	2380
Overall width	39.0	990.6	34.5	876.3
Road clearance	5.1	129.5	5.1	129.5
Overall height	61.0	1549.4	55.1	1399.5
Saddle height*	27.3	693.4	27.3	693.4

*With 180 lb. (81.7 kg) rider on seat.

Table 2-3. Weights: 2008 Police Models

ITEM	FLHTP		FLHP	
	LB.	KG.	LB.	KG.
Weight as shipped from factory	764	347	739	335
GVWR	1200	544	1200	544
GAWR front	500	227	500	227
GAWR rear	827	375	827	375

NOTE

Gross vehicle weight rating (GVWR) (maximum allowable loaded vehicle weight) and corresponding gross axle weight rating (GAWR) are printed on a label fixed to the bottom of the right front frame downtube.

NOTE

See [2.3 TIRES](#) for important information regarding tire data and tire inflation.

Table 2-4. Rear Air Suspension Pressures

SHOCK LOADING	RECOMMENDED PRESSURES	
	PSI 0-35	kPa 0-241
Solo rider up to 150 lbs. (68 kg)	0	0
Solo rider 150-200 lbs. (68-91 kg)	0-10	0-69
Solo rider 200-250 lbs. (91-113 kg)	5-15	35-103
At maximum GVWR	20-35	138-241

NOTE

Initial suspension fill pressure for a normally equipped police motorcycle is 25 psi (172.4 kPa).

GENERAL

See [Figure 2-1](#). The full 17-digit serial number, or Vehicle Identification Number (V.I.N.), is stamped on the right side of the frame backbone at the rear of the steering head (and under the main harness conduit). A label bearing the V.I.N. code is also affixed to the left side of the steering head. An abbreviated V.I.N. is stamped between the front and rear cylinders on the left side of the crankcase.

Sample V.I.N. as it appears on the steering head - **1HD1FHM137Y110000**

Sample abbreviated V.I.N. as it appears on the crankcase - **FHM7110000**

NOTE

Always give the complete V.I.N. when ordering parts or making an inquiry about your motorcycle.

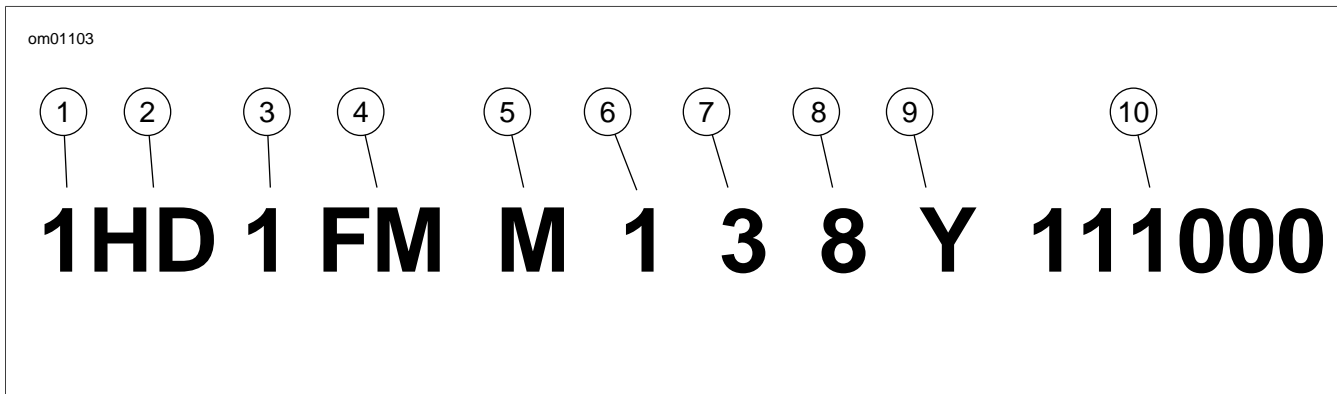

Figure 2-1. Typical Harley-Davidson V.I.N.: 2008 Police Models

Table 2-5. Harley-Davidson V.I.N. Breakdown: 2008 Police Models

POSITION	DESCRIPTION	POSSIBLE VALUES
1	Market designation	1=Originally manufactured for sale within the United States 5=Originally manufactured for sale outside of the United States
2	Manufacturer	HD=Harley-Davidson
3	Motorcycle type	1=Heavyweight motorcycle (901cc or larger)
4	Model	See V.I.N. model table
5	Engine type	M=Twin Cam 103™ 1690cc air-cooled, fuel injected
6	Introduction date	1=Regular 2=Mid-year 3=California/regular 4=Cosmetic changes and/or special introductory date 5=California/cosmetic changes and/or special introductory date 6=California/mid-year
7	V.I.N. check digit	Can be 0-9 or X
8	Model year	8=2008
9	Assembly plant	Y=York, PA U.S.A.
10	Sequential number	Varies

Table 2-6. V.I.N. Model Codes: 2008 Police Models

CODE	MODEL
FM	FLHTP
FH	FLHP
FT	FLHPE

GENERAL

The rear tire on FL police model motorcycles is fit for solo riding only. If converted to a two-up bike, that is, configured for passenger use (with luggage), then the rear tire needs to be changed to one with a higher weight rating. Since it has long been Harley-Davidson policy not to mix different types of tires on the same vehicle, we strongly recommend that both front and rear tires be replaced. In order to alert the customer to this safety issue, the following warning appears on a label fitted to the rear fender approximately 1/4 inch (6.4 mm) behind the domestic seat mounting hole.

WARNING

This vehicle has tires with weight ratings for one person operation. If this vehicle is modified to carry two people, the tires must be changed. See a Harley-Davidson dealer for proper replacement tires. Using improper tires can cause tire failure which could result in death or serious injury. (00096a)

NOTE

Use the tires recommended for civilian/pleasure vehicles of the same year and model family.

WARNING

Harley-Davidson front and rear tires are not the same. Interchanging front and rear tires can cause tire failure, which could result in death or serious injury. (00026a)

Tire size, manufacturer's description and inflation pressure are listed below.

NOTE

ABS motorcycles must always use tires and wheels that are the same as the original equipment. The ABS monitors the rotational speed of the wheels through individual wheel speed sensors. Changing to different diameter wheels or different size tires can alter the rotational speed. This can upset the calibration of the ABS and have an adverse effect on its ability to detect and prevent lockups. Tire inflation pressure that is significantly low also can have an adverse effect.

Table 2-7. Tire Data

TIRE LOCATION	SIZE	MANUFACTURER'S DESIGNATION	TIRE PRESSURE (COLD)
Front	MT90B 16 72H	Dunlop D402F PT	36 psi (248 kPa)
Rear	MT90B 16 72H	Dunlop D402 PT	36-40 psi (248-276 kPa)
All 2008 vehicles use only Dunlop Harley-Davidson tires.			

GENERAL

CAUTION

Maximum air pressure for the seat is 100 psi (689 kPa). Normal air pressure is 30-45 psi (207-310 kPa). Do not operate with air pressure so low that system bottoms out on bumpy roads. (00167a)

NOTES

- Initially pressurize the seat air suspension system to 40 psi (275.8 kPa), then add or remove pressure to the rider's comfort. DO NOT operate motorcycle with system under-inflated.
- To check minimum air pressure, have rider sit on seat and bounce to simulate riding conditions. Visually check for any contact between air spring and frame components. Add air as necessary.
- See [Figure 2-2](#). Removal and installation of retaining pin (1) requires that the air pressure be removed from the seat air suspension system. The seat will no longer pivot up because the front of the seat will hit the fuel tank. Retaining pin (1) should not be removed unless the seat is to be removed.
- The seat does not adjust forward or rearward.

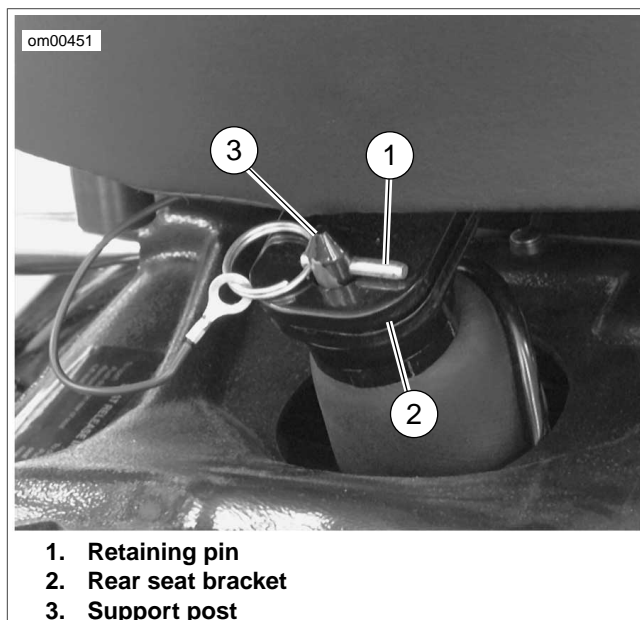
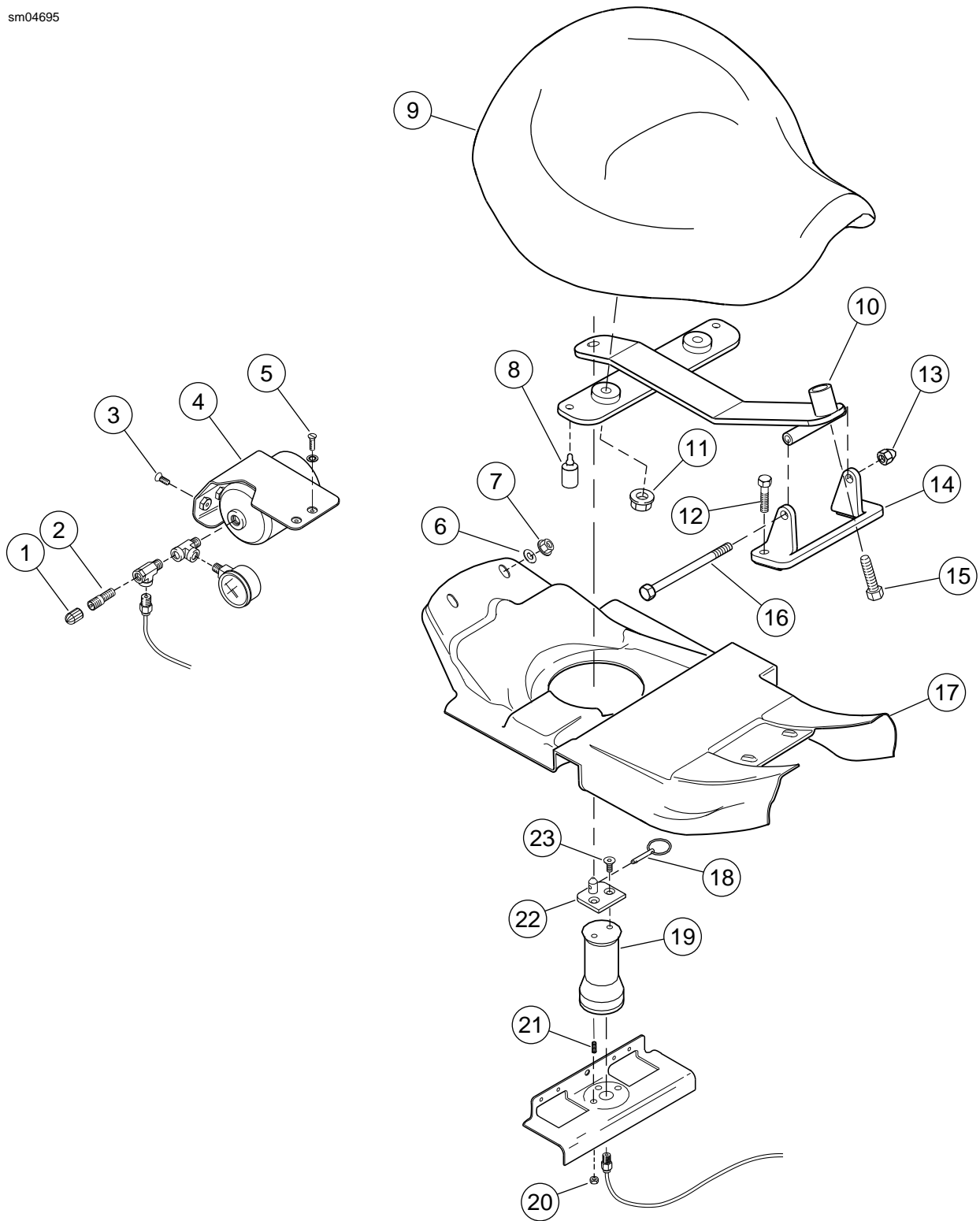

Figure 2-2. Seat Latch: Police Models



- | | | |
|----------------------|------------------------|-------------------|
| 1. Cap | 9. Seat | 17. Seat fairing |
| 2. Air fitting | 10. Seat bracket | 18. Retaining pin |
| 3. Fastener (2) | 11. Flange nut (2) | 19. Air spring |
| 4. Air reservoir | 12. Fastener (2) | 20. Nut (2) |
| 5. Fastener (2) | 13. Acorn Nut | 21. Set screw |
| 6. Flat Washer | 14. Seat bracket mount | 22. Top plate |
| 7. Flange nut (2) | 15. Hex scrwe | 23. Fastener |
| 8. Rubber bumper (2) | 16. Pivot bolt | |

Figure 2-3. Air Seat Assembly

SEAT REMOVAL

1. Remove air pressure from air spring and reservoir.
2. See [Figure 2-2](#). Standing on left side of motorcycle, press down on rear of seat and pull pin (1) from post (3) on top plate.
3. See [Figure 2-3](#). Remove front pivot bolt (16) and nut (13).
4. Lift seat and bracket assembly from motorcycle.
5. Remove two flange nuts (11) and hex screw (15) to release seat from seat bracket (10).
6. Inspect two rubber bumpers (8) on seat bracket for cuts, tears or general deterioration. If damaged, deteriorated or missing, replace as follows:
 - a. Remove old rubber bumper and discard.
 - b. Moisten bead on **new** rubber bumper with soapy water. Place rubber bumper into position at bottom of seat bracket. Feed tail on bead up through hole in seat bracket. Using a needle nose pliers, grasp tail as close to bead as possible, and then pull bead up through hole in seat bracket.
7. If necessary, remove two flange nuts (7) and washers (6) and remove seat fairing (17) under seat.

SEAT INSTALLATION

1. See [Figure 2-3](#). If removed, install seat fairing (17) under seat. Tighten flange nuts (7) to 60-120 **in-lbs** (6.8-13.6 Nm).
2. Install seat onto seat bracket and start two flange nuts (11). Align threaded hole in seat with hole in front of seat bracket and start hex screw (15).
3. Tighten flange nuts to 96-144 **in-lbs** (10.9-16.3 Nm).
4. Tighten hex screw to 60-120 **in-lbs** (6.8-13.6 Nm).
5. Place seat and bracket assembly on motorcycle and install front pivot bolt (16). Tighten nut (13) to 48-84 **in-lbs** (5.4-9.5 Nm).
6. See [Figure 2-2](#). Align post (3) on top plate with hole in rear seat bracket. While pressing down on rear of seat, insert pin (1) into post on top plate.

CAUTION

Maximum air pressure for the seat is 100 psi (689 kPa). Normal air pressure is 30-45 psi (207-310 kPa). Do not operate with air pressure so low that system bottoms out on bumpy roads. (00167a)

7. Fill air reservoir to 40 psi (275.8 kPa), then add or remove pressure to the rider's comfort. Install protective cap on air fitting.

AIR SPRING REPLACEMENT

Removal

1. Remove seat and seat fairing. See [2.4 SEAT, Seat Removal](#).

WARNING

Disconnect negative (-) battery cable first. If positive (+) cable should contact ground with negative (-) cable connected, the resulting sparks can cause a battery explosion, which could result in death or serious injury. (00049a)

2. Disconnect battery, negative (-) cable first.
3. Remove battery from battery box.
4. Remove air pressure from air spring and reservoir.
5. Depress collar on compression fitting and remove air tube from air reservoir.
6. See [Figure 2-3](#). Holding air spring to prevent twisting, remove two fasteners (23) to release top plate (22) from air spring (19).
7. Remove two flange nuts (20) under frame weldment (at rear of battery box). Remove air spring from motorcycle.

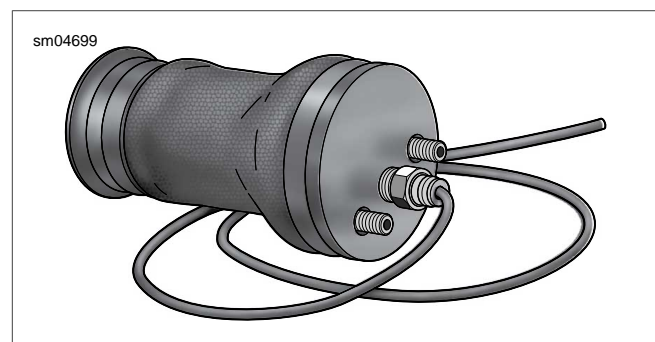

Figure 2-4. Air Spring Assembly

Installation

1. Feed air tube through large center hole in frame weldment (at rear of battery box) and then route rearward following inboard side of right upper frame tube to air reservoir.
2. Depress collar on compression fitting of air seat reservoir, and insert air tube until it bottoms. Gently tug on tube to verify that it is locked in place.
3. Connect air tube to compression fitting at bottom of air spring, if removed.
4. See [Figure 2-3](#). Place air spring on frame weldment while engaging the two set screws.
5. Install two flange nuts (20) onto set screws (21). Tighten flange nuts to 50-70 **in-lbs** (5.7-7.9 Nm).
6. Position top plate (22) onto air spring and start two fasteners (23). Holding air spring to prevent twisting, tighten screws to 36-60 **in-lbs** (4.1-6.8 Nm).
7. Place battery into battery box, terminal side forward.

WARNING

Connect positive (+) battery cable first. If positive (+) cable should contact ground with negative (-) cable connected, the resulting sparks can cause a battery explosion, which could result in death or serious injury. (00068a)

8. Connect battery cables, positive (+) cable first. Tighten to 60-96 **in-lbs** (6.8-10.9 Nm).
9. Apply a light coat of petroleum jelly or ELECTRICAL CONTACT LUBRICANT, Part No. 99861-02 (1 oz. tube), to both battery terminals.
10. Install hold-down clamp so that the lip (with rubber pad) rests on the edge of the battery. Tighten T40 TORX screw to 15-20 ft-lbs (20-27 Nm).
11. Install seat fairing. Tighten fasteners to 60-120 **in-lbs** (6.8-13.6 Nm).
12. Install seat and insert pin into post on top plate or air spring. See [2.4 SEAT, Seat Installation](#).

CAUTION

Maximum air pressure for the seat is 100 psi (689 kPa). Normal air pressure is 30-45 psi (207-310 kPa). Do not operate with air pressure so low that system bottoms out on bumpy roads. (00167a)

13. Fill air reservoir to 40 psi (275.8 kPa), then add or remove pressure to the rider's comfort. Install protective cap on air valve.

SEAT BRACKET MOUNT REPLACEMENT

Removal

1. Remove seat. See [2.4 SEAT, Seat Removal](#).
2. See [Figure 2-3](#). Remove two fasteners (12) to release seat bracket mount from frame backbone.

Installation

1. Install seat bracket mount using two fasteners (12). Tighten fasteners to 15-20 ft-lbs (20.3-27.1 Nm).
2. Install seat and insert pin into post on top plate of air spring. See [2.4 SEAT, Seat Installation](#).

REMOVAL

1. Remove both saddlebags.
2. On the right side of the motorcycle, locate the air seat reservoir air valve under the luggage rack, and on the left side, the rear shock air valve just below the chrome frame cover. See [Figure 2-5](#) and [Figure 2-6](#).

WARNING

Use caution when bleeding air from the suspension. Moisture combined with lubricant may leak onto the rear wheel, tire and/or brake components and adversely affect traction, which could result in death or serious injury. (00084a)

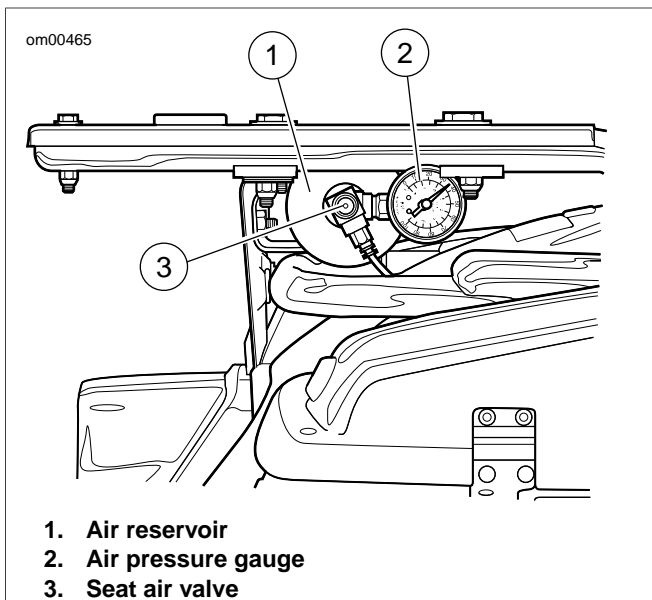

Figure 2-5. Seat Air Valve: Police Models

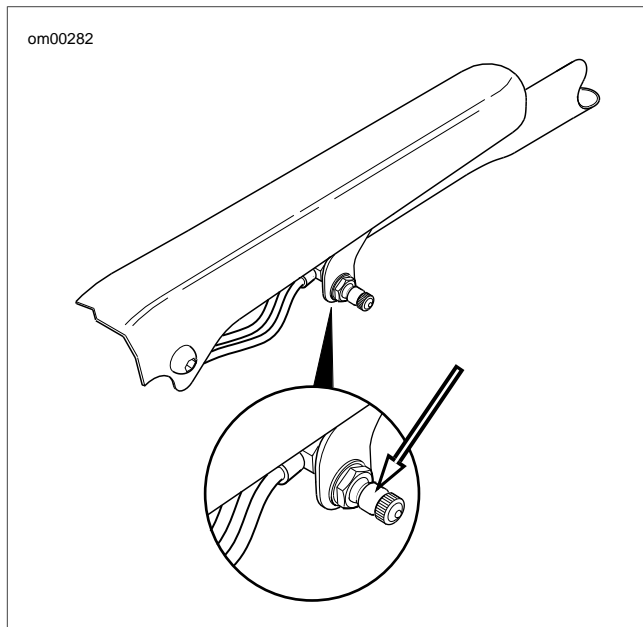

Figure 2-6. Rear Air Suspension Air Valve

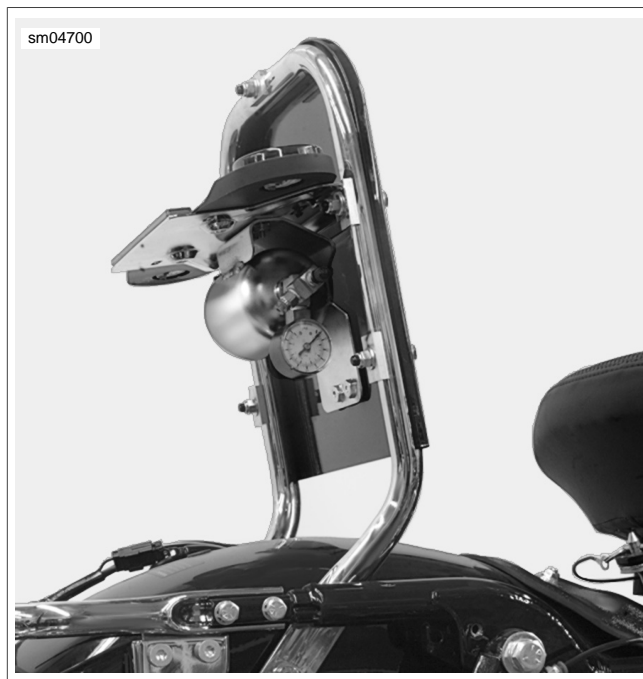

Figure 2-7. Raise Luggage Rack

3. Remove protective cap from each air valve and depress pin to bleed air from both reservoir and shocks. To purge rear air suspension lines of any oil, add 3-5 psi (20.7-34.5 kPa) before releasing air. Depress collar on each compression fitting and pull out air tube.
4. Remove bolt (with flat washer) to remove saddlebag front mounting bracket from chrome frame tube cover. Remove

- Phillips screw and chrome frame tube cover. Repeat step on opposite side of motorcycle.
- At inboard side of rear marker lights bracket, carefully pull left and right rear marker lights connectors.
 - Remove two hex bolts to free license plate bracket from bottom support tube.
 - Remove T40 TORX screws (with spacers) on each side of motorcycle to release ends of luggage rack from frame tube weldments.
 - Raise luggage rack high enough to access air reservoir. See [Figure 2-7](#).
 - Remove two Phillips screws (with external tooth lockwashers) from mounting plate (pole lamp) at top of luggage rack to release air reservoir bracket.
 - Remove two Phillips screws from license plate bracket to free rear of air reservoir bracket. Be sure to hold reservoir as the last screw is removed or damage to fender paint can occur if assembly is dropped. See [Figure 2-8](#).
 - Remove fittings and/or air pressure gauge from reservoir, if necessary.

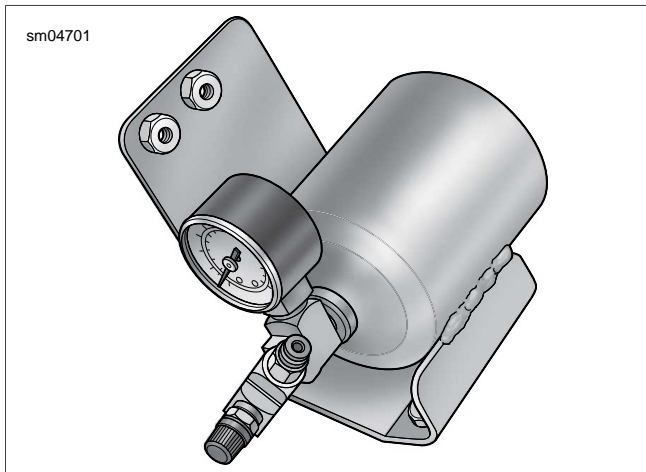

Figure 2-8. Air Seat Reservoir Assembly

INSTALLATION

PART NUMBER	TOOL NAME
HD-34633	AIR SUSPENSION PUMP AND GAUGE

- Reassemble fittings and/or air pressure gauge onto air reservoir, if removed. Orient parts as shown in [Figure 2-8](#). Apply PIPE SEALANT WITH TEFLON to threads before assembly.
- Position air reservoir beneath luggage rack exercising caution to avoid scratching fender paint.
- Slide two Phillips screws through holes in license plate bracket engaging weld nuts at rear of air reservoir bracket. Alternately tighten screws to 20-30 **in-lbs** (2.3-3.4 Nm).
- Slide two Phillips screws (with external tooth lockwashers) through holes in mounting plate (pole lamp) at top of luggage rack engaging weld nuts at top of air reservoir

bracket. Alternately tighten screws to 20-30 **in-lbs** (2.3-3.4 Nm).

- Place luggage rack into position inboard of frame tubes.
- Install T40 TORX screws (with spacers) on each side of motorcycle to secure ends of luggage rack to frame tube weldments. Alternately tighten screws to 15-20 ft-lbs (20.3-27.1 Nm).
- Install two hex bolts to fasten license plate bracket to bottom support tube. Alternately tighten screws to 15-20 ft-lbs (20.3-27.1 Nm).
- At inboard side of rear marker lights bracket, connect left and right rear marker lights connectors.
- Install chrome frame tube cover on frame tube. Install Phillips screw and tighten to 25-40 **in-lbs** (2.8-4.5 Nm). Repeat step on opposite side of motorcycle.
- Install bolt (with flat washer) to install saddlebag front mounting bracket, but do not tighten. Repeat step on opposite side of motorcycle.
- Depress collar on compression fitting of air seat reservoir, and insert air tube until it bottoms. Gently tug on tube to verify that it is locked in place.

CAUTION

Maximum air pressure for the seat is 100 psi (689 kPa). Normal air pressure is 30-45 psi (207-310 kPa). Do not operate with air pressure so low that system bottoms out on bumpy roads. (00167a)

- Fill air reservoir to 40 psi (275.8 kPa), then add or remove pressure to the rider's comfort. Install protective cap on air valve. See [Figure 2-5](#).

NOTE

To set minimum air pressure, have rider sit on seat and bounce to simulate riding conditions. Visually check for any contact between air spring and frame components. Add air as necessary.

- Observe air pressure gauge. If leakage occurs, then remove tube and inspect end for burrs or damage. If either condition is found, snip off end of tube and insert back into fitting.
- Depress collar on compression fitting of each shock and insert air tube until it bottoms. Gently tug on tube to verify that it is locked in place.

CAUTION

Do not exceed maximum air pressure for rear suspension. Air components fill rapidly. Therefore, use low air line pressure. Failure to do so may result in possible damage to components. (00165a)

NOTE

Initial suspension fill pressure for a normally equipped police motorcycle is 25 psi (172.4 kPa).

- Fill shocks to 25 psi (172.4 kPa), then add or remove pressure to the rider's comfort. Refer to [Table 2-8](#).

Table 2-8. Rear Air Suspension Pressures

SHOCK LOADING	RECOMMENDED PRESSURES	
	PSI 0-35	kPa 0-241
Solo rider up to 150 lbs. (68 kg)	0	0
Solo rider 150-200 lbs. (68-91 kg)	0-10	0-69
Solo rider 200-250 lbs. (91-113 kg)	5-15	35-103
Maximum GVWR (see 2.1 SPECIFICATIONS: CHASSIS)	20-35	138-241

⚠ WARNING

Do not exceed the motorcycle's Gross Vehicle Weight Rating (GVWR) or Gross Axle Weight Rating (GAWR). Exceeding these weight ratings can affect stability and handling, which could result in death or serious injury. (00016e)

NOTE

An AIR SUSPENSION PUMP AND GAUGE (Part No. HD-34633) is available at your Harley-Davidson dealer.

16. Observe air pressure gauge while filling. If leakage occurs, remove tubes and inspect ends for burrs or damage. If either condition is found, snip off end of tube and insert back into fitting.
17. When air pressure remains constant, install protective cap on air valve.
18. Install saddlebags. Tighten saddlebag front mounting bracket bolts to 60-96 **in-lbs** (6.8-10.8 Nm).

LOCKSET

Removal

1. At inside of saddlebag lid, remove hex nut, internal tooth lockwasher, cam hook and cam washer. Remove jam nut and lock guide. See [Figure 2-9](#).
2. At outside of saddlebag lid, remove lockset. See [Figure 2-10](#).

Installation

1. With cam stop facing outboard side of saddlebag lid, install lockset into hole. See [Figure 2-10](#).
2. Install lock guide over threaded body of lockset oriented with finger on inboard side of saddlebag lid and pointing toward bottom. See [Figure 2-9](#).
3. Install jam nut and tighten to 30-45 **in-lbs** (3.4-5.1 Nm).
4. Verify that groove in threaded stud of lockset is facing inboard side of saddlebag lid. Use key to rotate threaded stud, if necessary.
5. Align cam hook and cam washer as shown in [Figure 2-10](#). With the cam hook toward the outboard side of saddlebag lid and cam washer on the inboard side, slide assembly down threaded stud.
6. Install internal tooth lockwasher and hex nut onto threaded stud. Tighten hex nut to 25-35 **in-lbs** (2.8-4.0 Nm).

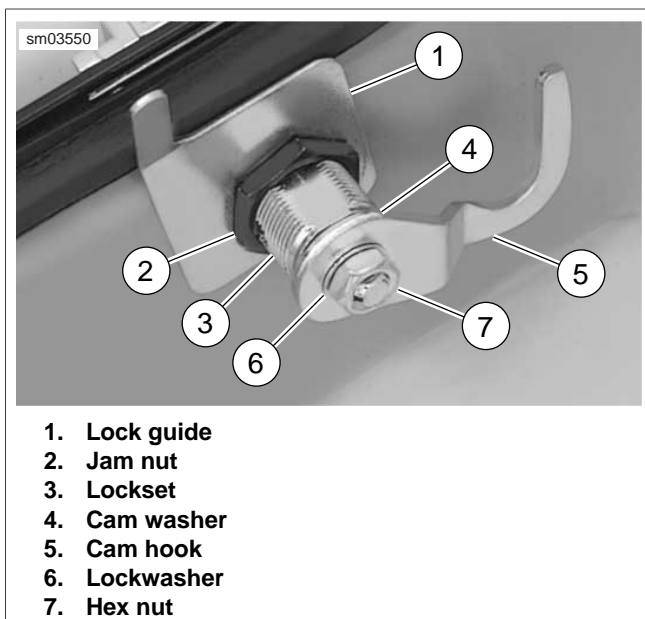

Figure 2-9. Lockset Assembly

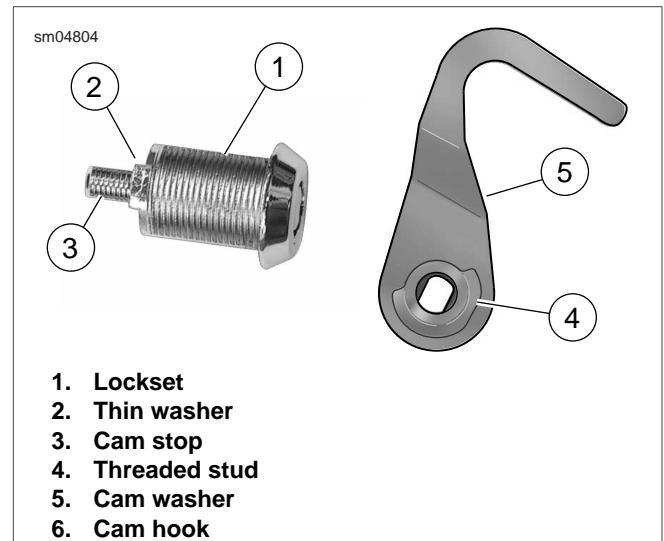

Figure 2-10. Lockset Mechanism

LOCKSET CATCH

Removal

1. Drill out two rivets using a 5/32 inch drill bit.
2. Remove backplate, lockset catch and flat washers.

Installation

1. Slide two **new** rivets through holes in backplate, saddlebag, lockset catch and flat washers.
2. Compress rivets using a suitable rivet tool.

HINGES

PART NUMBER	TOOL NAME
HD-39787A	RIVET TOOL

Removal

1. Remove tether. See [2.6 SADDLEBAGS, Tether](#).
2. Drill off peened end of hinge pin rivet using a 3/8 inch drill bit. Use a punch to tap rivet shaft out of hinge.
3. Drill out eight rivets using a 3/16 inch drill bit.
4. Remove hinge and backplates.

sm03552

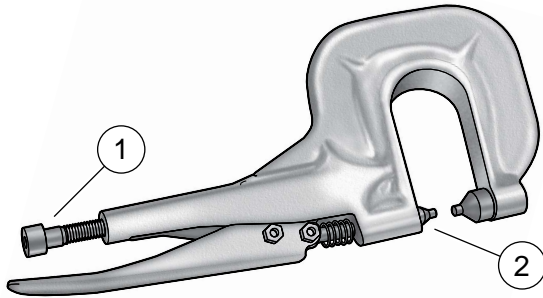

1. Adjuster thumbscrew
2. Drive head

Figure 2-11. Rivet Tool (HD-39787A)

Installation

1. Slide **new** rivet through holes in hinge, saddlebag and backplate.
2. Obtain RIVET TOOL (Part No. HD-39787A). See [Figure 2-11](#).
3. Orient tool so that head of rivet is seated in depression of drive head. Turn adjuster thumbscrew in or out of handle until both ends of rivet are captured.
4. Slowly squeeze handle of tool to compress rivet. Turn adjuster thumbscrew slightly in a clockwise direction and then squeeze handle again to further compress rivet. Repeat step as necessary until rivet is fully installed.

NOTE

Compress rivet in small increments only. This method provides for best retention and alignment of parts and avoids possible damage to tool and painted surfaces of saddlebag.

5. Repeat previous steps to install remaining rivets.
6. Install lid onto saddlebag engaging upper and lower hinges.
7. Compress **new** hinge pin rivet using a suitable rivet tool.
8. Install tether. See [2.6 SADDLEBAGS, Tether](#).

TETHER

Removal

NOTE

When the tether is removed, use caution to keep lid from opening beyond its normal travel or damage to painted surfaces or hinges can occur.

1. Remove T15 TORX screw from threaded boss on tether bracket. See [Figure 2-12](#).
2. Remove tether eyelet and wave spring from threaded boss.

3. Repeat previous steps to remove opposite end of tether from second tether bracket.

Installation

1. With the concave side toward the tether bracket, install wave spring onto threaded boss.
2. Install tether eyelet onto threaded boss.
3. Apply a small dab of LOCTITE HIGH STRENGTH THREADLOCKER 262 (red) to threads of T15 TORX screw.
4. Install screw into threaded boss and tighten to 20-25 **in-lbs** (2.3-2.8 Nm). See [Figure 2-12](#).
5. Repeat this procedure to fasten opposite end of tether to second tether bracket.

sm04702

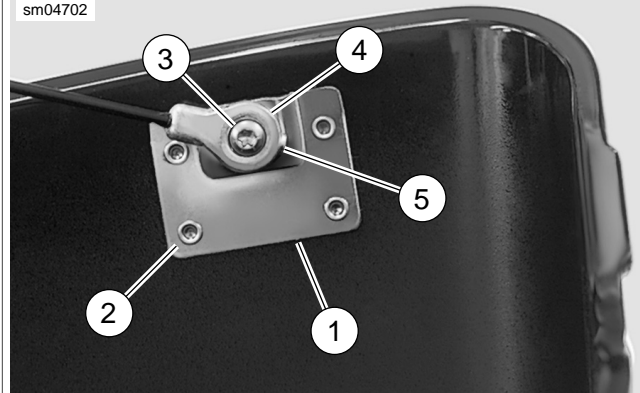

1. Tether bracket
2. Rivet (4)
3. T15 TORX screw
4. Tether eyelet
5. Wave spring

Figure 2-12. Tether and Tether Bracket

TETHER BRACKETS

Removal

1. Remove tether. See [2.6 SADDLEBAGS, Tether](#)
2. Drill out four rivets using a 3/16 inch drill bit.
3. Remove tether bracket and backplate.

Installation

1. Slide **new** rivets through holes in backplate, saddlebag/saddlebag lid and tether bracket (with the threaded boss on the outboard side).
2. Install rivets. See [2.6 SADDLEBAGS, Hinges](#).
3. Install tether. See [2.6 SADDLEBAGS, Tether](#).

KNOB AND SPRING LATCH

Removal

1. Place multiple strips of masking tape on each side of knob to protect finished surfaces from scratches and other damage. Using a large flat blade screwdriver, alternately pry up each side of knob until free of post. See upper frame of [Figure 2-13](#).

- Remove knob seal and masking tape. Remove any residual adhesive with 3M general Purpose adhesive remover (Part No. 051135). See lower frame of [Figure 2-13](#).
- Drill out two rivets using a 13/64 inch drill bit. Remove spring latch. See [Figure 2-14](#).

Installation

- Hold spring latch at bottom of saddlebag lid with the flat side facing opposite the hinges. See [Figure 2-14](#).
- Slide two **new** rivets through holes in saddlebag lid and spring latch.
- Compress rivets using a suitable rivet tool.
- Peel paper backing off adhesive side of knob seal. Place knob seal over post, so that the adhesive side contacts the saddlebag lid. Press knob seal firmly into place.
- Install knob onto post and alternately work each side down until it bottoms.

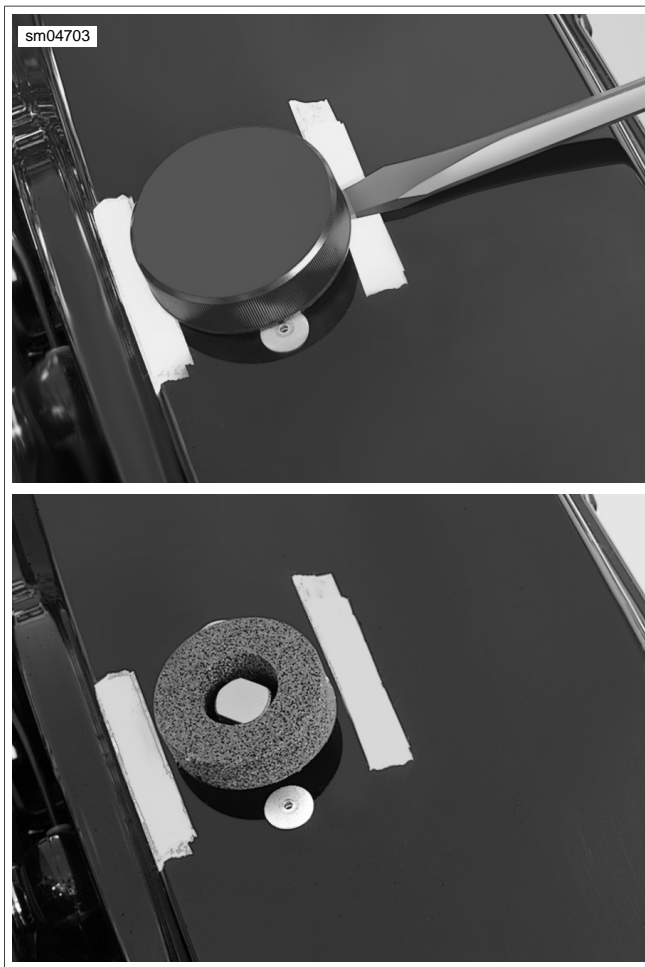

Figure 2-13. Saddlebag Knob and Seal

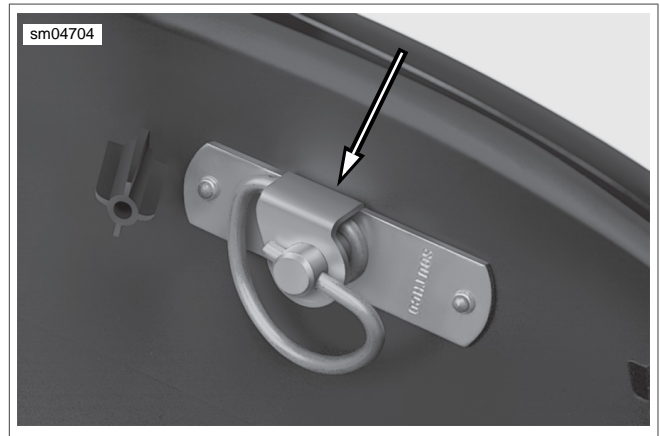

Figure 2-14. Spring Latch

SPRING LATCH BRACKET

Removal

- From outside saddlebag, loosen two Phillips screws.
- Inside saddlebag, remove two Keps nuts and spring latch bracket. Remove Phillips screws. See [Figure 2-15](#).

Installation

- From outside saddlebag, slide two Phillips screws through holes in saddlebag.
- Inside saddlebag, install spring latch bracket and two Keps nuts. See [Figure 2-15](#).
- Alternately tighten Phillips screws until snug.

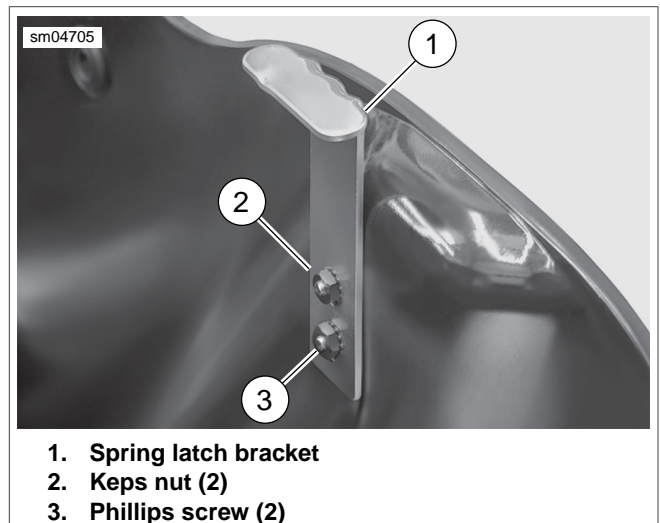

Figure 2-15. Spring Latch Bracket

REMOVAL

NOTE

The two rear holes in the handlebar clamp shroud allow the rider to adjust the handlebars without having to remove the shroud. To keep out moisture and debris, be sure to install plastic plugs back into holes after handlebar adjustment. See [Figure 2-18](#).

1. Remove windshield. See WINDSHIELD: FLHR/C in the Touring Models Service Manual.
2. Remove Phillips screw at bottom of headlamp door (chrome ring). Remove headlamp door.
3. Remove seven Phillips screws to free headlamp housing from headlamp nacelle.
4. Remove headlamp connector at back of headlamp bulb. Remove headlamp housing assembly from motorcycle.
5. From inside the headlamp nacelle:
 - a. Disconnect tachometer harness connector [20], 6-place Deutsch. See [Figure 2-16](#).
 - b. Remove flange nut from weld stud to release chrome strip at top of nacelle.
 - c. Catch Keps nut and flat washer while removing Phillips screw from tab at front of handlebar clamp shroud.
6. Carefully pry off the fork lock plate at the rear of the handlebar clamp shroud. Remove two Phillips screws beneath the lock plate.
7. Remove the handlebar clamp shroud from the motorcycle, while gently pulling the tachometer harness conduit and connector out of the headlamp nacelle.
8. Remove two acorn nuts (with flat washers) to release tachometer bracket from studs at top of handlebar clamp shroud.

NOTE

Do not operate ABS equipped motorcycles with the tachometer removed. While the ABS remains operational, the rider will receive no warning if a malfunction occurs. The means to report DTC's also will be eliminated.

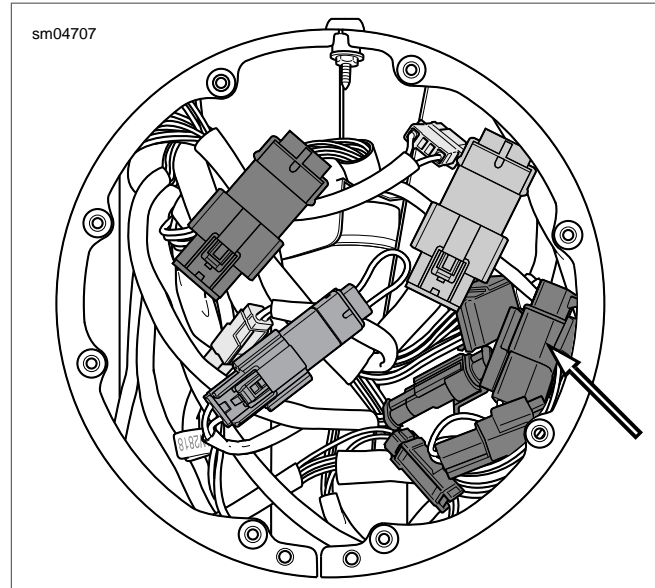

Figure 2-16. Disconnect Tachometer Connector

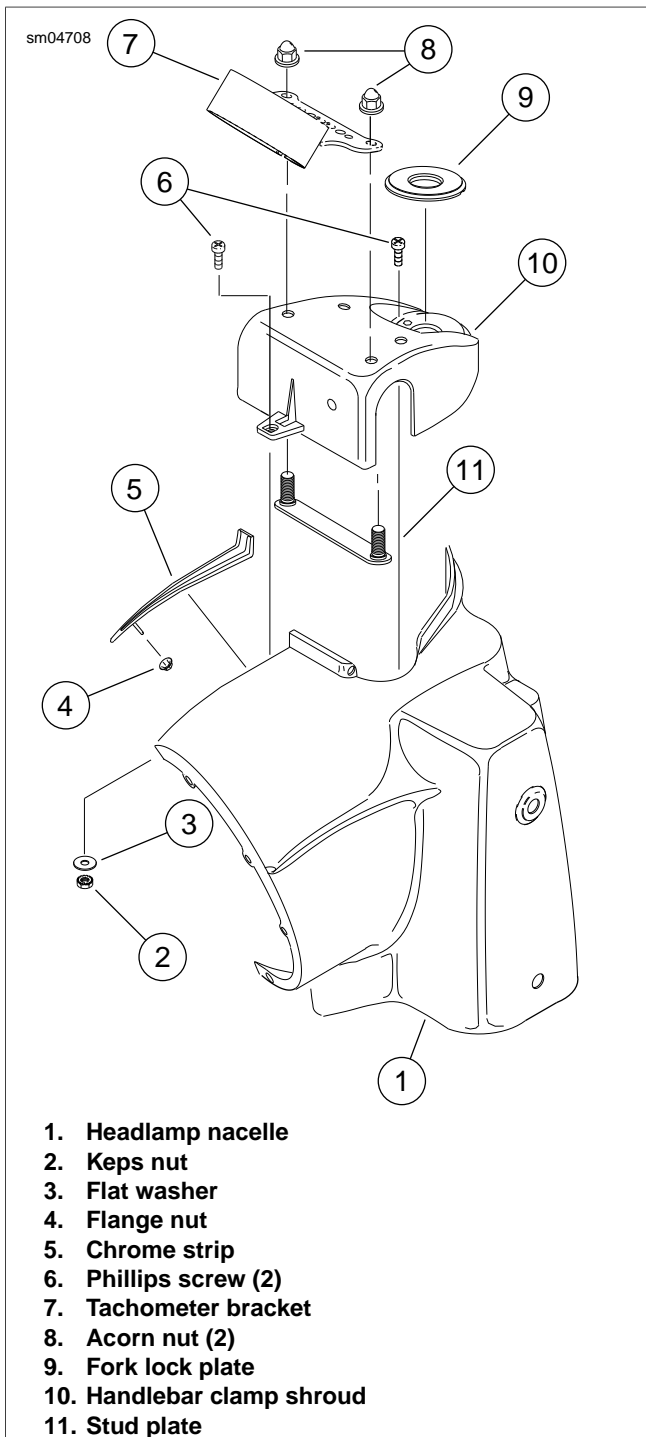

Figure 2-17. Headlamp Nacelle Assembly

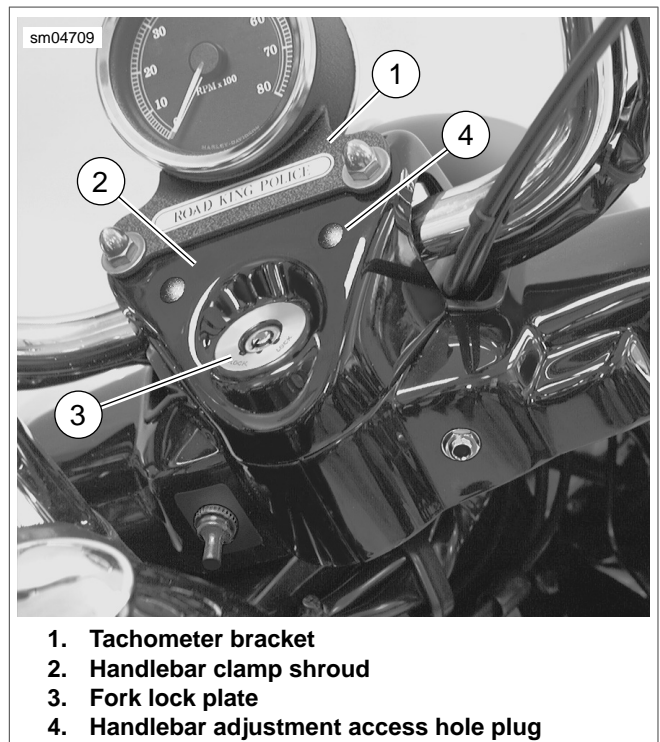

Figure 2-18. Install Handlebar Clamp Shroud

INSTALLATION

1. Place tachometer bracket over studs at top of handlebar clamp shroud. Install two acorn nuts (with flat washers) onto studs and alternately tighten to 72-108 **in-lbs** (8.1-12.2 Nm). See [Figure 2-18](#).

NOTE

A peel and stick foam tape on the stud plate holds it in place on the inboard side of the handlebar clamp shroud.

2. Feed tachometer harness connector and conduit through opening at top of headlamp nacelle. Install handlebar clamp shroud over mating flange while routing tachometer harness conduit through opening for left side handlebar.
3. From inside the headlamp nacelle:
 - a. Start flat washer and Keps nut onto Phillips screw installed in tab at front of handlebar clamp shroud. Tighten Phillips screw to 10-20 **in-lbs** (1.1-2.3 Nm). See [Figure 2-17](#).
 - b. Install flange nut onto weld stud of chrome strip installed into hole at the top of headlamp nacelle. Tighten flange nut to 15-20 **in-lbs** (1.7-2.3 Nm).
 - c. Connect tachometer harness connector [20], 6-place Deutsch. See [Figure 2-16](#).
4. Install two Phillips screws to fasten handlebar clamp shroud to the fork lock mechanism. Install fork lock plate.
5. Install headlamp connector at back of headlamp bulb.
6. Align holes in headlamp housing with those in headlamp nacelle (headlamp door bracket at bottom). Install seven Phillips screws and alternately tighten to 9-18 **in-lbs** (1.0-2.0 Nm).

7. Fit the square-shaped portion of the headlamp door spring into slot at top of headlamp housing and then snap the headlamp door (chrome ring) into place. Install Phillips screw at bottom of headlamp door and tighten to 9-18 **in-lbs** (1.0-2.0 Nm).
8. Install windshield. See WINDSHIELD: FLHR/C in the Touring Models Service Manual.

SUBJECT	PAGE NO.
3.1 SPECIFICATIONS: ENGINE.....	3-1
3.2 SERVICE WEAR LIMITS.....	3-2
3.3 OIL COOLER.....	3-3

NOTES

GENERAL

Table 3-1. Engine: 2008 Police Models

ITEM	SPECIFICATION	
Number of cylinders	2	
Type	4-cycle, 45 degree V-Type, air cooled	
Compression ratio	9.6-1	
Bore	3.875 in.	98 mm
Stroke	4.375 in.	111 mm
Displacement	103 cu. in.	1690 cc
Torque	102 ft-lbs @ 2500 RPM	138 Nm @ 2500 RPM

Table 3-2. Oiling System

ITEM	SPECIFICATION
Pump	Twin gerotor, dual scavenge, crank mounted and driven, internal oil pump, dry sump
Pressure	30-38 psi (207-262 kN/m ²) at 2000 RPM and normal operating temperature of 230° F (110° C)
Filtration	10 micron media, filtered between pump and engine
Cooling	Thermostat controlled oil cooler

MANUFACTURING TOLERANCES

Table 3-3. Valves

ITEM	IN.	MM
Fit in guide (exhaust)	0.0015-0.0033	0.038-0.084
Fit in guide (intake)	0.0008-0.0026	0.020-0.066
Stem protrusion from cylinder head boss	1.990-2.024	50.55-51.41

Table 3-4. Valve Spring Assembly

ITEM	PRESSURE	DIMENSION
Closed	165 lbs (75 kg)	1.820 in. (46.2 mm)
Open	416 lbs (189 kg)	1.290 in. (32.7 mm)
Free length	n/a	2.210 in. (56.1 mm)

Table 3-5. Connecting Rods

ITEM	INCHES	MM
Piston pin fit (loose)	0.0003-0.0007	0.008-0.018

Table 3-6. Crankshaft/Sprocket Shaft Bearing

ITEM	INCHES	MM
Bearing inner race on crankshaft (tight)	0.0001-0.0010	0.0025-0.0254

GENERAL

Wear limits can be used as a guide when deciding whether to reuse engine parts. Replace used parts whenever the following wear limits are exceeded.

Table 3-7. Cam Support Plate

ITEM	REPLACE IF WEAR EXCEEDS	
	INCHES	MM
Cam chain tensioner shoe	0.080-0.090	2.03-2.29
Warping	0.010	0.25
Crankshaft bushing fit	0.0008-0.001	0.0203-0.0254

Table 3-8. Cylinder Bore

ITEM	REPLACE IF WEAR EXCEEDS	
	INCHES	MM
Standard	3.877	98.48
0.005 in. oversize	3.882	98.60
0.010 in. oversize	3.887	98.73

Table 3-9. Connecting Rods

ITEM	REPLACE IF WEAR EXCEEDS	
	INCHES	MM
Piston pin fit (loose)	0.001	0.025

Table 3-10. Crankshaft/Sprocket Shaft Bearing

ITEM	REPLACE IF WEAR EXCEEDS	
	INCHES	MM
Crankshaft runout	Greater than 0.003	Greater than 0.076
Bearing fit in crankcase (tight)	0.0038-0.0054	0.097-0.137
Bearing inner race on crankshaft (tight)	Less than 0.0001	Less than 0.0254

Table 3-11. Valve Stem to Guide Clearance

ITEM	REPLACE IF WEAR EXCEEDS	
	INCHES	MM
Intake	0.0035	0.089
Exhaust	0.0040	0.102

OPERATION

Pressurized oil flows through a hole in the oil filter mount into a passage in the oil cooler adapter. The oil cooler adapter is mounted between the oil filter mount and the oil filter.

A thermostat inside the oil cooler adapter controls the flow of oil to the oil cooler. The thermostat consists of a temperature sensitive element compressed between a spring and threaded plug. See [Figure 3-1](#).

While the engine oil temperature is below 200° F (93° C), the thermostat is open allowing most of the engine oil to pass from the supply port directly to the return port en route to the oil filter.

When the engine oil temperature reaches 200° F (93° C), the thermostat closes and the entire flow is directed to the oil cooler through the supply hose.

The fins on the tubes of the oil cooler dissipate heat before the flow returns to the oil cooler adapter through the return hose. The engine oil then passes through the oil filter before returning to the crankcase.

NOTE

For a complete description of the engine oil flow, see *GENERAL INFORMATION* in the *Touring Models Service Manual*.

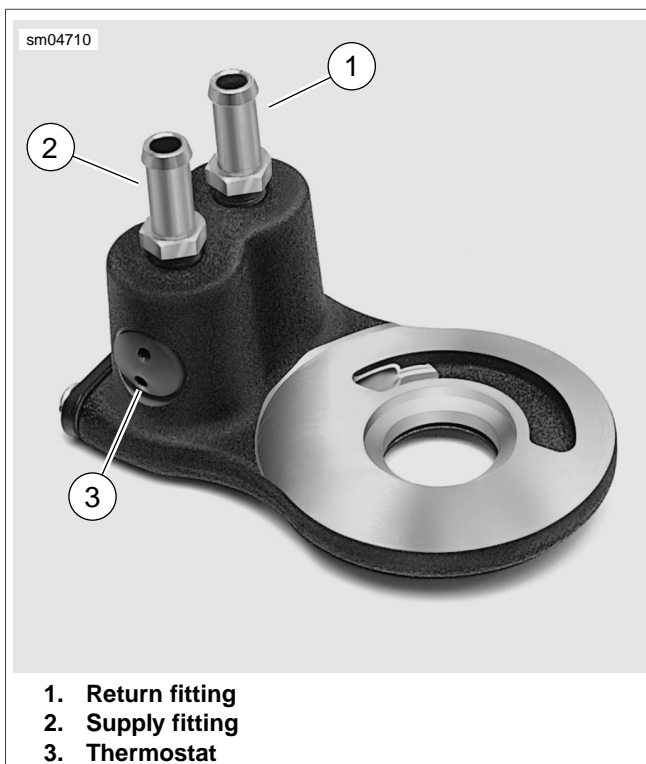

Figure 3-1. Oil Cooler Adapter

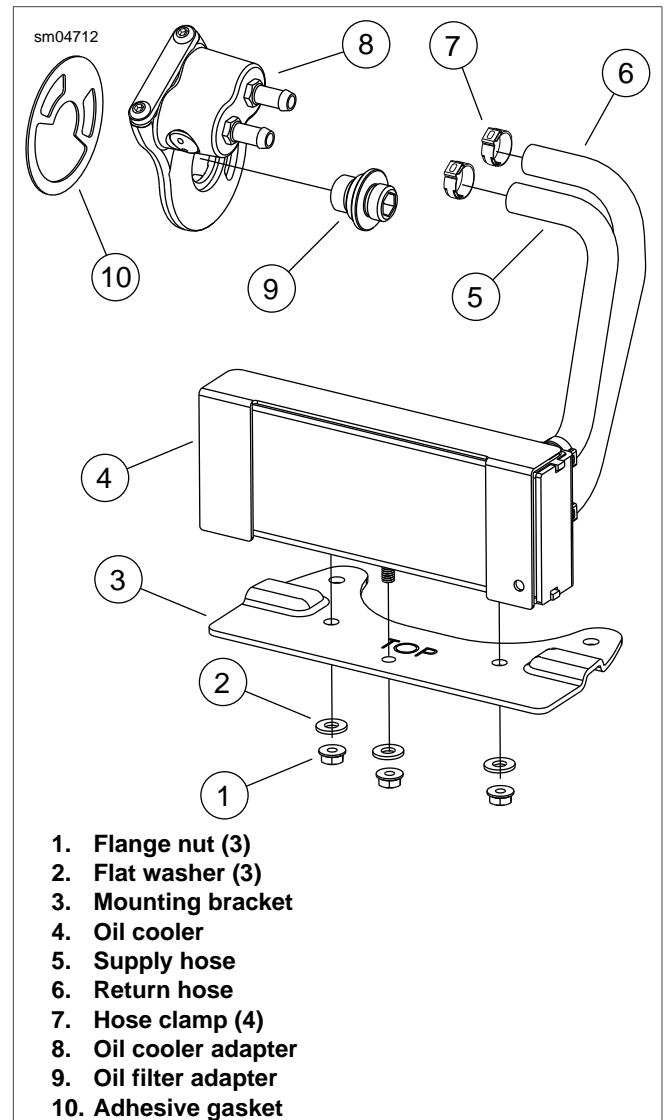

Figure 3-2. Oil Cooler Assembly

REMOVAL

1. Place a suitable drain pan beneath the oil cooler.
2. See [Figure 3-2](#). Remove three flange nuts with flat washers. Raise oil cooler to free threaded studs from holes in mounting bracket.
3. Using a side cutters, cut and remove clamps on oil cooler adapter side of supply and return hoses. Pull hoses from fittings.
4. Remove oil cooler from motorcycle.
5. Using a side cutters, cut and remove clamps on oil cooler side of supply and return hoses. Pull hoses from fittings.

6. Remove mounting bracket as follows:
 - a. Remove voltage regulator and front electrical caddy. See VOLTAGE REGULATOR in the Touring Models Service Manual.
 - b. Lift mounting bracket off studs on lower frame cross-member.

CLEANING AND INSPECTION

1. Using a clean shop cloth or soft bristle brush, gently clean oil cooler fins of dirt and debris.
2. If engine failure and/or oil contamination requires inspection and cleaning of oil passageways, then remove oil cooler adapter and proceed as follows:
 - a. See [Figure 3-3](#). Remove two socket screws (3) to release inspection cover (4) and gasket (2).
 - b. Thoroughly flush oil passageways with solvent and blow out with compressed air.
 - c. Install inspection cover with new gasket.
 - d. Apply a small dab of Loctite Medium Strength Threadlocker 243 (blue) to threads of socket screws. Install screws and alternately tighten to 90-120 **in-lbs** (10.2-13.6 Nm).

INSTALLATION

PART NUMBER	TOOL NAME
HD-97087-65B	HOSE CLAMP PLIERS

NOTE

If mounting bracket is already installed, proceed to next step.

1. Install mounting bracket as follows:
 - a. With the "TOP" stamp facing upward, install mounting bracket onto studs on lower frame crossmember.
 - b. Install front electrical caddy and voltage regulator. See VOLTAGE REGULATOR in the Touring Models Service Manual.
2. Slide new clamp onto oil cooler side of return hose, which can be identified by the paint stamp reading COOLER BOTTOM. With the script facing upward, install hose onto bottom fitting of oil cooler. Crimp clamp using HOSE CLAMP PLIERS (Part No. HD-97087-65B).
3. Slide new clamp onto oil cooler side of supply hose, which can be identified by the paint stamp reading COOLER TOP. With the script facing upward, install hose onto top fitting of oil cooler. Crimp clamp.

NOTE

If the paint stamps are not present, the long hose is the return and the short hose is the supply. Install both hoses, so that the 90° bend goes to the oil cooler adapter.

4. Slide threaded studs at bottom of oil cooler through holes in mounting bracket. Install flat washers and flange nuts on studs. Alternately tighten flange nuts to 70-100 **in-lbs** (7.9-11.3 Nm).
5. Slide new clamp onto free end of return hose (stamped COOLER BOTTOM). Install hose on upper fitting of oil cooler adapter. Crimp clamp using HOSE CLAMP PLIERS (Part No. HD-97087-65B).

6. Slide new clamp onto free end of supply hose (stamped COOLER TOP). Install hose on lower fitting of oil cooler adapter. Crimp clamp.
7. Check engine oil level. See ENGINE OIL AND FILTER in the Touring Models Service Manual.

OIL COOLER ADAPTER AND THERMOSTAT REPLACEMENT

PART NUMBER	TOOL NAME
HD-97087-65B	HOSE CLAMP PLIERS

Removal

NOTE

A faulty thermostat requires replacement of the oil cooler adapter.

1. Place a suitable drain pan beneath the oil cooler and oil filter.
2. Using a side cutters, cut and remove clamps on oil cooler adapter side of supply and return hoses. Pull hoses from fittings.
3. Remove the engine oil filter. See ENGINE OIL AND FILTER in the Touring Models Service Manual.
4. Using internal hex, remove the oil filter adapter. Remove the oil cooler adapter and gasket. See [Figure 3-2](#).

Installation

NOTE

Skip first step if hose fittings are already installed.

1. Install hose fittings as follows:
 - a. Install hose fittings until finger tight.
 - b. Using wrench on flats, rotate hose fittings an additional 2-3 turns.
2. Position oil cooler adapter flange against oil filter mount. Index tabs on flange engage a recess on each side of the oil filter mount oil outlet hole. See [Figure 3-3](#).
3. Apply Loctite High Temperature/Medium Strength Threadlocker 246 to threads of oil filter adapter. With the internal hex on the outboard side, thread oil filter adapter into oil filter mount. Holding the oil cooler adapter to prevent rotation, tighten oil filter adapter to 18-22 ft-lbs (24.4-29.8 Nm).
4. Slide new clamp onto free end of return hose (stamped COOLER BOTTOM). Install hose on upper fitting of oil cooler adapter. Crimp clamp using HOSE CLAMP PLIERS (Part No. HD-97087-65B).
5. Slide new clamp onto free end of supply hose (stamped COOLER TOP). Install hose on lower fitting of oil cooler adapter. Crimp clamp.
6. Install new oil filter and check engine oil level. See ENGINE OIL AND FILTER in the Touring Models Service Manual.
7. Start engine and inspect oil cooler/adapter fittings and hoses for leaks.



Figure 3-3. Oil Cooler Adapter

NOTES

SUBJECT

4.1 FUEL SYSTEM.....

PAGE NO.

4-1

NOTES

NO UNIQUE CONTENT

Any information not presented in this supplement can be found in the Touring Models Service Manual.

NOTES

SUBJECT

5.1 ELECTRIC STARTER.....

PAGE NO.

5-1

NOTES

NO UNIQUE CONTENT

Any information not presented in this supplement can be found in the Touring Models Service Manual.

NOTES

SUBJECT

6.1 DRIVE.....

PAGE NO.

6-1

NOTES

NO UNIQUE CONTENT

Any information not presented in this supplement can be found in the Touring Models Service Manual.

NOTES

SUBJECT

7.1 TRANSMISSION.....

PAGE NO.

7-1

NOTES

NO UNIQUE CONTENT

Any information not presented in this supplement can be found in the Touring Models Service Manual.

NOTES

SUBJECT	PAGE NO.
8.1 BULB CHART.....	8-1
8.2 SYSTEM FUSES AND RELAYS.....	8-3
8.3 REAR MARKER LIGHTS.....	8-5
8.4 HANDLEBAR SWITCHES.....	8-6
8.5 AUTOMATIC COMPRESSION RELEASE.....	8-10

NOTES

GENERAL

The table below gives the bulb requirements for FLHTP and FLHP/E police model motorcycles.

WARNING

The rear strobe is a source of high voltage and must be off at least 10 minutes before servicing. Inadequate safety precautions may result in death or serious injury. (00097a)

Table 8-1. Bulb Chart FLHTP, FLHP/E

LAMP DESCRIPTION (ALL LAMPS 12V)	NUMBER OF BULBS (REQUIRED)	CURRENT DRAW (AMPERAGE)	WATTAGE	HARLEY-DAVIDSON PART NUMBER
Head Lamp				
Low Beam	1	4.58	55	68329-03
Hlgh Beam		5.00	60	
Tail/Stop Lamp				
Tail Lamp	1	0.59	6	68167-88
Stop Lamp		2.10	24	
Turn Signal Lamp				
Front / Running	2	2.25 / 0.59	27/7	68168-89
Rear	2	2.25	27	68572-64B
Rear Fender Tip Lamp				
Rear Fender Tip Bulb	2	0.33	3.7	53439-79
Pursuit Lamp				
Left (Red)	1	2.5	30	68727-64A
Right (Blue)				68728-64
Rear Strobe, if provided		N/A	20	67598-88
Instrument Panel Lamps-FLHTP Indicator Module (with LEDs)				
High Beam Indicator**	N/A	0.05	N/A	68859-07
Oil Pressure Indicator**				
Neutral Indicator**				
Turn Signal Indicator**				
Gauge Lamps-FLHTP				
Speedometer**	N/A	N/A	N/A	N/A
Tachometer**				
Voltmeter	1	0.24	3.4	67445-00
Fuel Gauge				
Engine**	N/A	N/A	N/A	N/A
Pursuit (fairing)	1	0.08	1.1	68642-96
Instrument/Gauge Lamps-FLHP/E Indicator Module (with LEDs)				
High Beam Indicator**	N/A	0.05	N/A	68113-99B
Oil Pressure Indicator**				
Neutral Indicator**				
Turn Signal Indicator**				

Table 8-1. Bulb Chart FLHTP, FLHP/E

LAMP DESCRIPTION (ALL LAMPS 12V)	NUMBER OF BULBS (REQUIRED)	CURRENT DRAW (AMPERAGE)	WATTAGE	HARLEY-DAVIDSON PART NUMBER
Fuel Gauge**	N/A	N/A	N/A	N/A
Speedometer**				
Odometer**				
Engine**				
Pursuit**				
** LED illuminated. LEDs are not repairable. Assembly must be replaced if LED fails.				

SYSTEM FUSES

Removal

1. Verify that the Ignition/Light Key Switch is turned to the OFF position.
2. Remove left side saddlebag.
3. See [Figure 8-1](#). Remove wing nut style bolt to release bottom of siren amplifier mounting bracket from clamp on saddlebag guard. Rotate bracket upward to gain complete access to side cover area. Loosen top bolt, if necessary.
4. Gently pull side cover from frame downtubes (no tools required). Exercise caution to avoid scratching side cover on amplifier mounting bracket.
5. Raise the fuse block cover.

NOTE

The fuse block cover has a fuse puller attachment that may be used to remove fuses.

6. Remove fuse from fuse block and inspect the element.
7. See [Figure 8-2](#) to identify fuse location. Replace fuse if element is burned or broken. Automotive type ATO fuses are used.

CAUTION

Always use replacement fuses that are of the correct type and amperage rating. Use of incorrect fuses can result in damage to electrical systems. (00222a)



Figure 8-1. Siren Amplifier Mounting Bracket

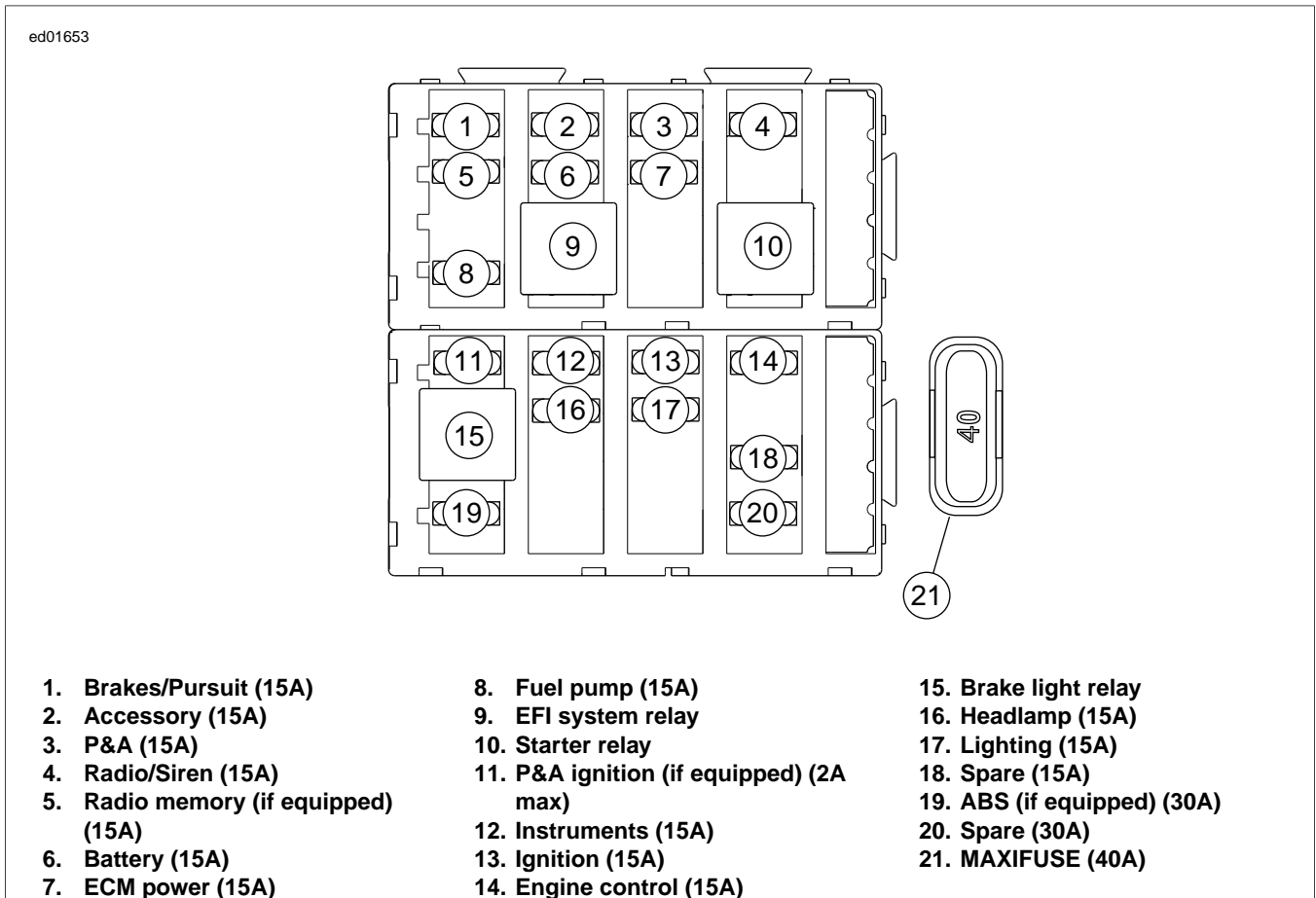

Figure 8-2. Left Side Electrical Caddy

Installation

1. Install fuse in fuse block. For correct type and amperage rating, refer to [Figure 8-2](#).
2. Install cover on fuse block.
3. Align barbed studs in side cover with grommets in frame downtubes and push firmly into place (no tools required).
4. Rotate siren amplifier mounting bracket downward. Install wing nut style bolt to secure bracket to clamp on saddlebag guard. Tighten top bolt, if loosened.
5. Install left side saddlebag.

MARKER LIGHTS REPLACEMENT

1. On inboard side of rear marker lights bracket, gently pull electrical connector from prongs on marker light.
2. Rotate marker light in a counterclockwise direction and remove from hole in rear marker lights bracket.
3. Place new marker light into hole in rear marker lights bracket and rotate in a clockwise direction to install.
4. On inboard side of rear marker lights bracket, gently push electrical connector onto prongs on marker light.

REMOVAL

1. Disconnect rear marker lights harness connector [12], 3-place Multilock, inboard of left upper frame tube.
2. Carefully cut cable strap to release rear marker lights (and pole lamp) conduit from left side of bottom support tube.
3. On inboard side of license plate bracket, note that catches on rear marker lights bracket engage oblong holes in license plate bracket. Using tip of flat blade screwdriver, gently push top catch down and then bottom catch up to release from oblong hole. Repeat step to release other side of rear marker lights bracket.

4. Remove rear marker lights assembly from motorcycle.

INSTALLATION

1. Gently pull both electrical connectors from prongs to detach rear marker lights harness.
2. On inboard side of left upper frame tube, mate pin and socket housings of rear marker lights harness connector [12], 3-place Multilock.
3. Route free end of rear marker lights conduit rearward following inboard side of bottom support tube. When conduit reaches air reservoir, loop left side rear marker light conduit to outboard side, while routing right side rear marker light conduit between top of bottom support tube and bottom of air reservoir bracket to right side of motorcycle.
4. Engage catches on each side of rear marker lights bracket into oblong holes in license plate bracket.
5. On inboard side of rear marker lights bracket, gently push electrical connectors onto prongs on marker lights.
6. Install new cable strap to secure rear marker lights (and pole lamp) conduit to left side of bottom support tube. Cut any excess cable strap material.

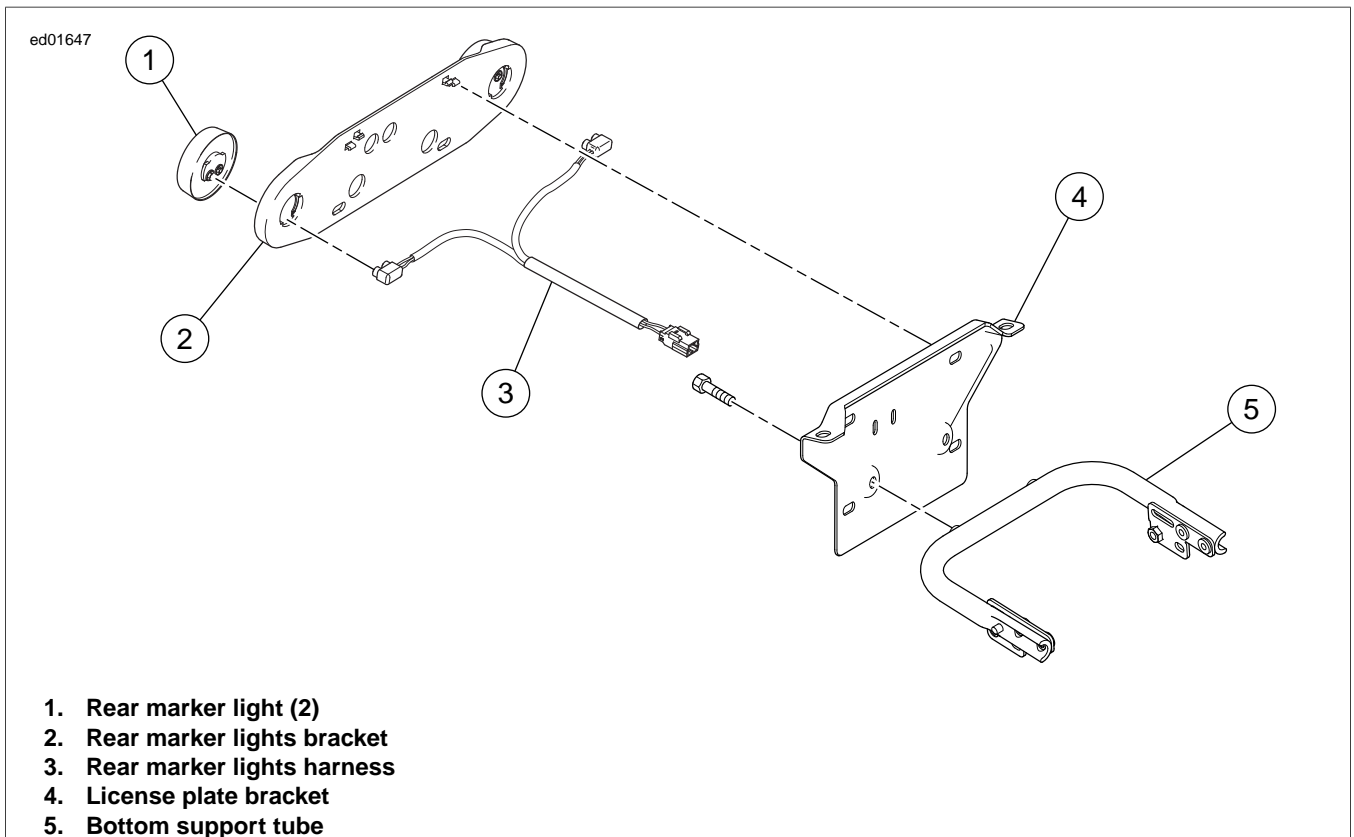

Figure 8-3. Rear Marker Lights Assembly

HORN AND SIREN YELP SWITCH

NOTE

Install new cable strap to secure rear marker lights (and pole lamp) conduit to left side of bottom support tube. Cut any excess cable strap material.

Removal

1. Gain access to the inside of the switch housing. See HANDLEBAR SWITCH ASSEMBLIES in the Touring Models Service Manual.
2. From inside the switch housing, carefully cut cable strap to free conduit from the turn signal switch bracket.
3. Remove the Phillips screw (with lockwasher) to release the turn signal switch bracket. Remove the switch assembly from the housing.
4. Remove the two T8 TORX screws and the Phillips screw (with lockwasher) to release the lower bracket. Carefully lift out the bracket so as not to disturb the spring-loaded ramp on the inboard side of the housing.
5. Carefully remove the keycap disengaging slot from hook on ramp.
6. While holding down the ramp, pull both switches from the housing.
7. Cut the wires from the old switches as follows:
 - a. Yellow/Black wire: 1-1/4 in. (32 mm)
 - b. Orange/White wires: 1-7/8 in. (48 mm)
 - c. Brown/Black wire: 1-1/2 in. (38 mm)

NOTE

Replacement Horn/Siren Yelp Switch wires are cut to length and partially stripped (Yellow/Black wire: 3-3/4 in. (95 mm); Orange/White wires: 3-1/2 in. (89 mm); Brown/Black wire: 3-3/8 in. (86 mm).

8. Connect wires of new switch. See HANDLEBAR SWITCH ASSEMBLIES in the Touring Models Service Manual.

NOTE

If the ramp and spring mechanism becomes loose, install as follows:

- Using the blade of a small screwdriver, compress spring and place in wider portion of channel at bottom of ramp.
- Verify that spring is evenly compressed and is not cocked or skewed. Push spring so that it bottoms in channel.
- With tab side of ramp facing inboard and hook end on switch side of casting, install ramp so that narrow channels engage pins cast into housing.

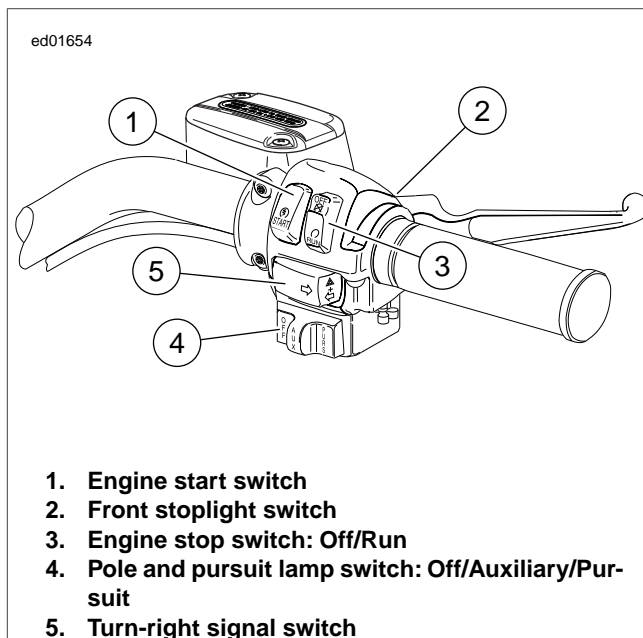

Figure 8-4. Right Handlebar Switch Housing

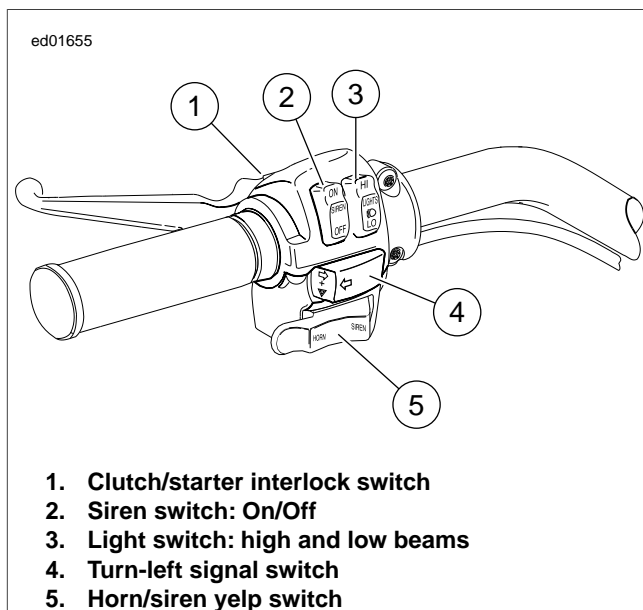

Figure 8-5. Left Handlebar Switch Housing

Installation

1. Install the switches in the housing with contacts facing tabs on ramp. For best results, install one switch at a time. Ribs cast in lower housing hold switches in position.

The Horn switch with the Yellow/Black lead (pivot point towards rider) is installed at the bottom, while the Siren Yelp switch with the Brown/Black lead (pivot point towards the front) is at the top. Route switch wires in channel on the outboard side of the ribbed area.

2. Install the keycap engaging slot with hook on ramp.
3. Install lower bracket sliding pin through keycap and engaging hole in lower casting.
4. Slide T8 TORX screws through holes in lower bracket and switches and thread into lower casting until snug.
5. Install Phillips screw (with lockwasher), to secure lower bracket to threaded boss in housing. Verify operation of Horn and Siren Yelp switches to ensure that both are spring returned.
6. Install clutch interlock switch in bore of lower switch housing, if loose.
7. Insert tapered end of new 7-inch cable strap into round hole in turn signal switch bracket and then feed back through using the adjacent hole. Reserve the oblong hole for the bracket screw.

NOTE

Be sure that all splices are positioned above the turn signal switch bracket.

8. Place the turn signal switch assembly into the housing aligning the oblong hole in the bracket with the lower bracket weld nut. Be sure that bracket is fully seated. Tabs on each side are captured in slots cast into switch housing.
9. Install Phillips screw (with lockwasher) to secure bracket inside housing.

CAUTION

If routed incorrectly, wires can be pinched by casting or handlebar resulting in switch failure. (00542b)

10. Loop switch wires so that spliced lengths are positioned directly over bracket screw.
11. Capturing conduit about 1/4 inch (6 mm) from end, securely tighten cable strap to draw conduit to bracket. Remove any excess cable strap material.
12. On opposite side, install second 7-inch cable strap capturing conduit and wire splices. Securely tighten cable strap to draw splices to conduit. Remove any excess cable strap material.
13. Route wire bundle to upper switch housing below and then forward of the main wire harness positioning conduit in channel next to angular arm of bracket. Secure bundle to arm placing new cable strap 1/4 inch (6 mm) from end of conduit. Cut any excess cable strap material. If necessary, bend angular arm of bracket downward to firmly secure clutch interlock switch in installed position.
14. See HANDLEBAR SWITCHES in the Touring Models Service Manual.

CLUTCH INTERLOCK SWITCH

NOTE

All Police models have a clutch interlock switch that prevents the motorcycle from starting (even in NEUTRAL) if the clutch lever is not pulled in.

Removal

1. See HANDLEBAR SWITCH ASSEMBLIES in the Touring Models Service Manual.

2. From inside the switch housing, carefully cut cable strap to free conduit from the turn signal switch bracket.
3. Remove the Phillips screw (with lockwasher) to release the turn signal switch bracket. Remove the switch assembly from the housing.
4. Remove the clutch interlock switch from the housing.
5. Cut wires 1/4 in. (6 mm) from old switch. Discard switch assembly.

NOTE

Replacement clutch interlock switch wires are cut to length. Looking at rear side, left side switch wire is 2-1/4 in. (57 mm), and right side is 2-3/4 in. (70 mm) and partially stripped.

6. Connect wires of new switch. See HANDLEBAR SWITCH ASSEMBLIES in the Touring Models Service Manual.

Installation

1. Install clutch interlock switch in bore of lower switch housing.
2. Insert tapered end of new 7-inch cable strap into round hole in turn signal switch bracket and then feed back through using the adjacent hole. Reserve the oblong hole for the bracket screw.

NOTE

Be sure that all splices are positioned above the turn signal switch bracket.

3. Place the turn signal switch assembly into the housing aligning the oblong hole in the bracket with the lower bracket weld nut. Be sure that bracket is fully seated. Tabs on each side are captured in slots cast into switch housing.
4. Install Phillips screw (with lockwasher) to secure bracket inside housing. If routed incorrectly, wires may be pinched by casting or handlebar resulting in switch failure.

CAUTION

If routed incorrectly, wires can be pinched by casting or handlebar resulting in switch failure. (00542b)

5. Loop switch wires so that spliced lengths are positioned directly over bracket screw.
6. Capturing conduit about 1/4 in. (6 mm) from end, securely tighten cable strap to draw conduit to bracket. Remove any excess cable strap material.
7. On opposite side, install second 7-inch cable strap capturing conduit and wire splices. Securely tighten cable strap to draw splices to conduit. Remove any excess cable strap material.
8. Route wire bundle to upper switch housing below and then forward of the main wire harness positioning conduit in channel next to angular arm of bracket. Secure bundle to arm placing new cable strap 1/4 in. (6 mm) from end of conduit. Cut any excess cable strap material. If necessary, bend angular arm of bracket downward to firmly secure clutch interlock switch in installed position.
9. See HANDLEBAR SWITCH ASSEMBLIES in the Touring Models Service Manual.

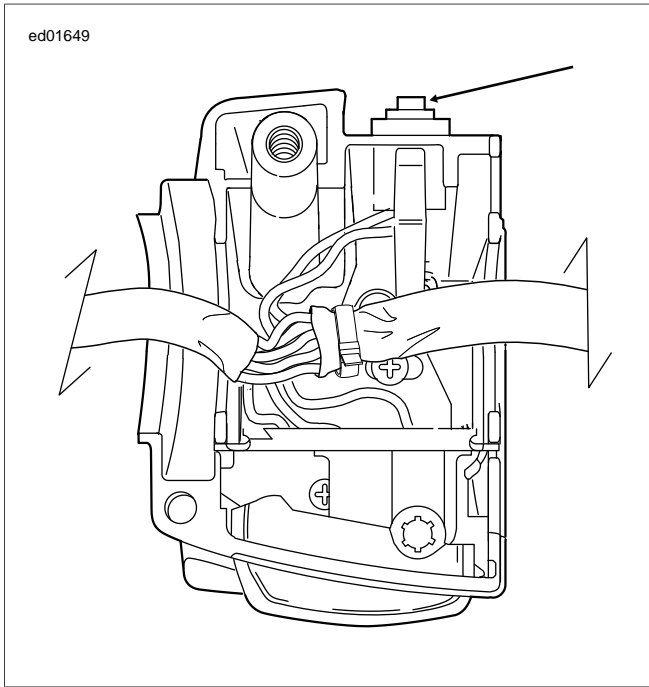

Figure 8-6. Lower Switch Housing

PURSUIT AND AUXILIARY SWITCH

NOTE

Pursuit lamps are operational on domestic motorcycles only.

Removal

1. See HANDLEBAR SWITCH ASSEMBLIES in the Touring Models Service Manual.
2. From inside the switch housing, carefully cut cable strap to free conduit from the turn signal switch bracket.
3. Remove the Phillips screw (with lockwasher) to release the turn signal switch bracket. Remove the switch assembly from the housing.
4. Remove the two T8 TORX screws and the Phillips screw (with lockwasher) to release the lower bracket. Remove the bracket from the housing.
5. Pull both switches from the housing.
6. Cut the wires from the old switches as follows:
 - a. Gray/Black wire: 1-1/2 in. (38 mm)
 - b. Orange/Violet wires: 1-7/8 in. (48 mm)
 - c. Green/Red wire: 1-1/4 in. (32 mm)

NOTE

Replacement pursuit/auxiliary switch wires are cut to length and partially stripped (Gray/Black wire: 2 in. (51 mm); Orange/Violet wires: 1-7/8 in. (48 mm); Green/Red wire: 1-3/4 in. (45 mm)).

7. Connect wires of new switch. See HANDLEBAR SWITCH ASSEMBLIES in the Touring Models Service Manual.
8. Move keycap to the OFF position. Install the switches in the housing with contacts facing the recessed area on the ramp. Ribs cast in lower housing hold switches in position.

The Auxiliary switch with the Gray/Black lead is installed at the bottom, while the Pursuit switch with the Green/Red lead is at the top. Route switch wires into corner space outside of the ribbed area.

NOTE

If the keycap and ramp mechanism requires replacement, install as follows:

- Slide ramp upward to remove from keycap shaft.
- Remove keycap from switch housing.
- Install spring into hole on inboard side of new keycap. Position ball on end of spring. Use a small amount of grease to hold ball in place.
- Install keycap so that ball engages detent in switch housing.
- Slide ramp over keycap shaft so that tongues on ramp engage grooves in keycap shaft.

Installation

1. Install lower bracket with the weld nut side down.
2. Slide the T8 TORX screws through holes in lower bracket and switches and thread into lower casting until snug.
3. Install Phillips screw (with lockwasher), to secure lower bracket to threaded boss in housing. Work Auxiliary and Pursuit switches to ensure smooth operation.
4. See [Figure 8-7](#). Insert tapered end of new 7-inch cable strap into round hole in turn signal switch bracket and then feed back through using the adjacent hole. Reserve the oblong hole for the bracket screw.

NOTE

Be sure that all splices are positioned above the turn signal switch bracket.

5. Place the turn signal switch assembly into the housing aligning the oblong hole in the bracket with the lower bracket weld nut. Be sure that bracket is fully seated. Tabs on each side are captured in slots cast into switch housing.
6. Install Phillips screw (with lockwasher) to secure turn signal switch bracket inside housing.

CAUTION

If routed incorrectly, wires can be pinched by casting or handlebar resulting in switch failure. (00542b)

7. Loop switch wires so that spliced lengths are positioned directly over bracket screw.
8. Capturing conduit about 1/4 in. (6 mm) from end, securely tighten cable strap to draw conduit to bracket. Remove any excess cable strap material.
9. On opposite side, install second 7-inch cable strap capturing conduit and wire splices. Securely tighten cable strap to draw splices to conduit. Remove any excess cable strap material.
10. Route wire bundle to upper switch housing in channel next to angular arm of bracket. Secure bundle to arm placing new cable strap 1/4 in. (6 mm) from end of conduit. Cut any excess cable strap material. If necessary, bend

angular arm of bracket downward to firmly secure Front Stoplight Switch in installed position.

11. See HANDLEBAR SWITCH ASSEMBLIES in the Touring Models Service Manual.

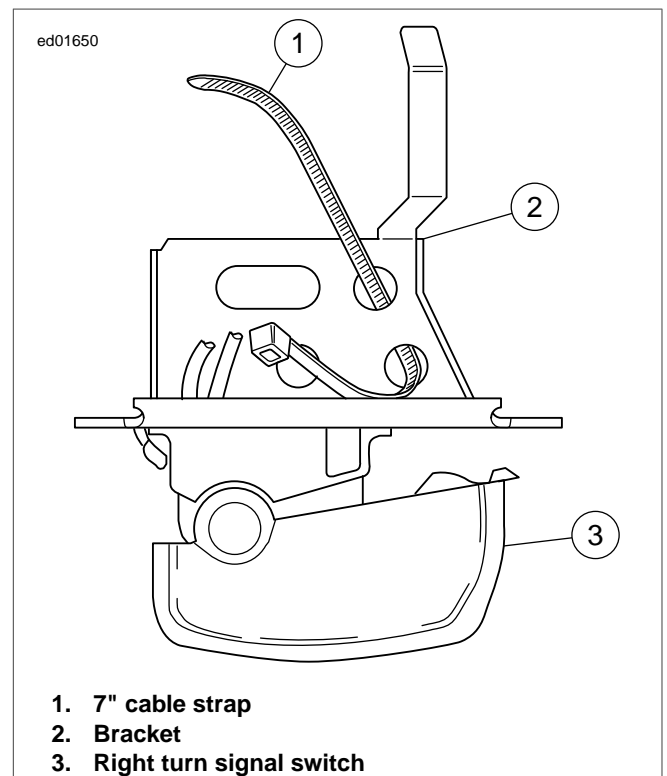

Figure 8-7. Hole Location Cable Strap Switch Bracket

GENERAL

See [Figure 8-8](#). The Automatic Compression Release (ACR) is opened and closed by the ECM to assist starting.

See [Figure 8-9](#). When open, compressed gases are released through the exhaust port.

REMOVAL

PART NUMBER	TOOL NAME
HD-48498	ACR SOLENOID SOCKET

1. While preparing motorcycle for service, separate the ACR rear [203R] and front [203F] connectors from the main wiring harness.
2. Remove the rocker cover and the rocker box. See STRIPPING MOTORCYCLE FOR SERVICE and TOP END OVERHAUL in the Service Manual for procedures.
3. See [Figure 8-13](#). Use ACR SOLENOID SOCKET (Part No. HD-48498) to remove the ACR from the cylinder head.

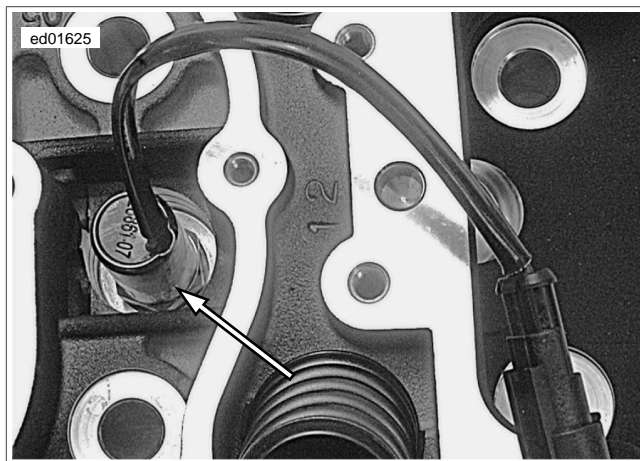

Figure 8-10. ACR in Head

INSTALLATION

PART NUMBER	TOOL NAME
HD-48498	ACR SOLENOID SOCKET

1. Verify that the copper seal washer is in place on the ACR.
2. See [Figure 8-11](#). Identify a location around the threads of the ACR approximately 1/3 of the way up from the end.
3. See [Figure 8-12](#). Apply three equally spaced dots of LOCTITE 246 THREADLOCKER MEDIUM STRENGTH/HIGH TEMPERATURE (blue) on threads.
4. To prevent cross threading, install and finger tighten.
5. See [Figure 8-13](#). Using ACR SOLENOID SOCKET (Part No. HD-48498), tighten to 11-15 ft-lbs (14.9-20.3 Nm).
6. Before installing the rocker box on each cylinder head, route the wire harness toward the inside of the cylinder V.
7. With rocker boxes installed and the engine in the chassis, mate the ACR connectors [203R] and [203F] to the corresponding socket housings on the main wiring harness.

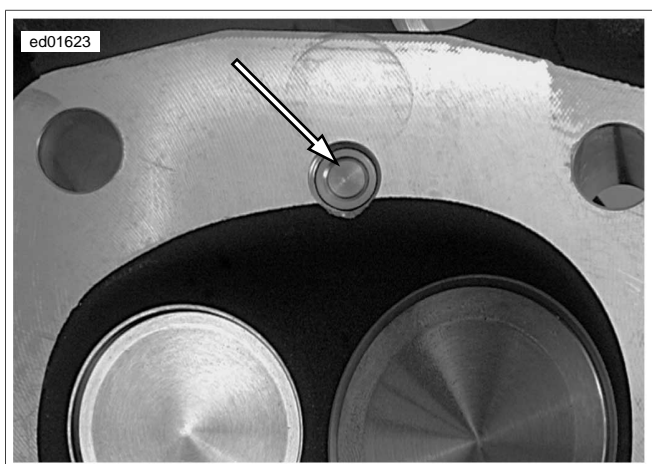

Figure 8-8. ACR Valve in Combustion Chamber

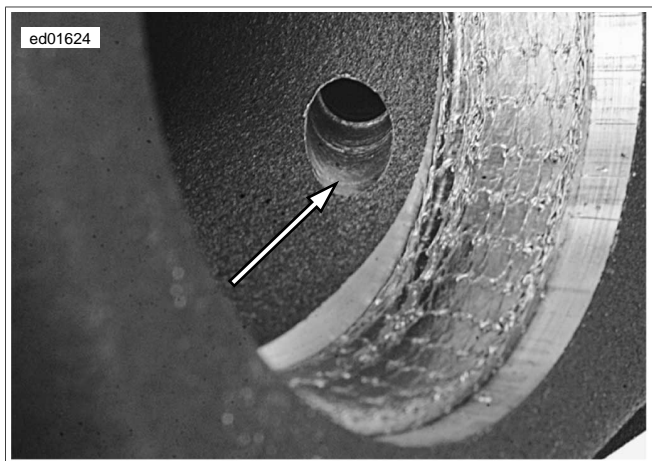

Figure 8-9. ACR Exhaust Port Release



Figure 8-11. Bottom Third

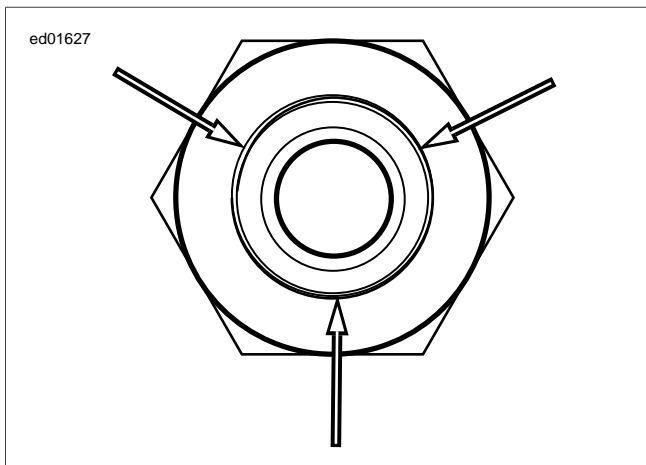

Figure 8-12. Three Dots of Loctite 246 Medium Strength/High Temperature



Figure 8-13. ACR Solenoid Socket (HD-48498) and ACR

COMPRESSION TEST

PART NUMBER	TOOL NAME
HD-33223-1	CYLINDER COMPRESSION GAUGE

A compression test can determine the source of cylinder leakage. Use CYLINDER COMPRESSION GAUGE (Part No. HD-33223-1) with a screw-in type adapter.

NOTE

The Twin Cam 103 Engine uses a 12 mm adapter with the compression gauge.

1. Operate engine to normal operating temperature.
2. Disconnect spark plug wires.
3. Clean around plug base and remove front cylinder spark plug.
4. Install compression tester to front cylinder per gauge instructions.

NOTE

The test results will vary depending on whether the ACR is connected or not. Refer to [Table 8-2](#) for specifications.

5. Shift transmission to neutral. Crank engine continuously through 5 to 7 compression strokes.
6. Record gauge readings at the end of the first and last compression strokes (highest readings).
7. Replace front spark plug and repeat test on rear cylinder.
8. Refer to [Table 8-2](#). Readings should be within specified range. If readings are higher than normal, suspect a compression release that is not functioning correctly. If readings are low, inject approximately 1/2 oz. (15 ml) engine oil into each cylinder and repeat the compression tests on both cylinders.

NOTE

Readings that are considerably higher after injecting the oil indicate worn piston rings.

Table 8-2. Compression Specifications

ACR STATUS	PSI	kN/m ²
Connected	130-170	896-1,173
Disconnected	200-220	1,379-1,517

DIAGNOSTICS

PART NUMBER	TOOL NAME
HD-41404-B	TEST CONNECTOR KIT
HD-48637	BREAK-OUT BOX

Diagnostic Tips

Refer to flow charts that follow for troubleshooting.

Diagnostic Notes

NOTE

The step numbers below correlate with the circled numbers in the flow chart.

1. Use TEST CONNECTOR KIT (Part No. HD-41404-B) with gray terminal probes and patch cords.
2. Connect BREAK-OUT BOX (Part No. HD-48637) to ECM.

3. If V/GY wire is shorted to ground, the ACRs will remain on for a time that exceeds the design parameters and the ACR solenoids will fail.

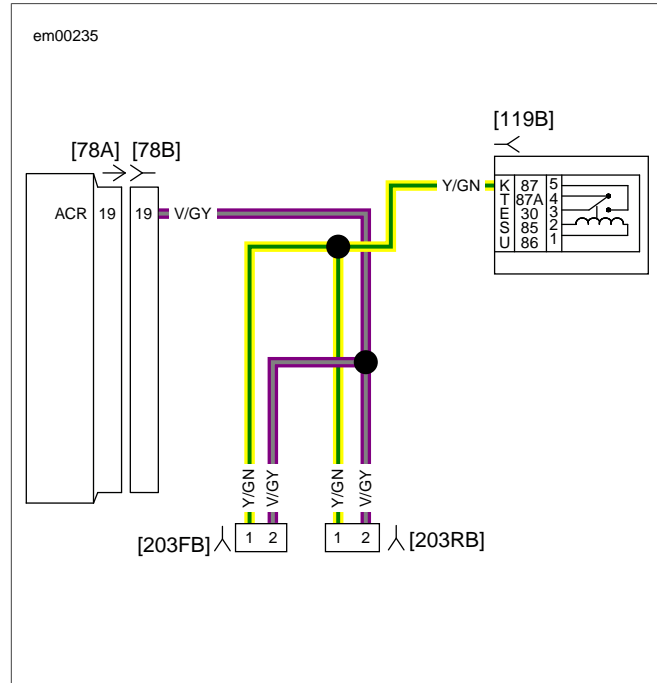
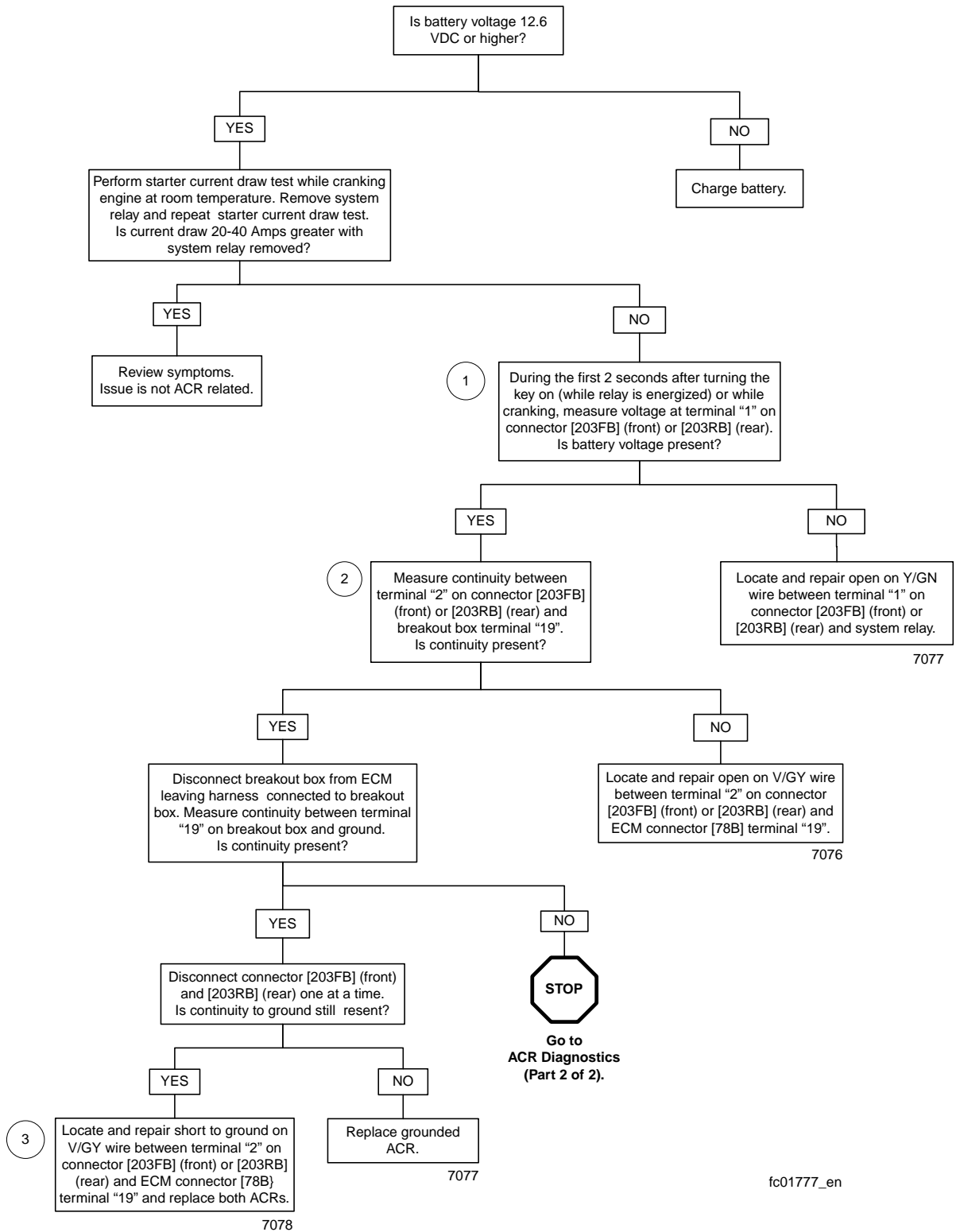

Figure 8-14. ACR Circuit

Table 8-3. Connectors/Fuse in ACR Circuit

NUMBER	DESCRIPTION	TYPE	LOCATION
[78]	ECM	73-place Delphi	Under seat
[203F]	ACR	2-place Amp (Tyco)	Between cylinders
[203R]	ACR	2-place Amp (Tyco)	Between cylinders
[119]	System relay	Lugs	ESPFI fuse block

ACR Diagnostics (Part 1 of 2)



ACR Diagnostics (Part 2 of 2)

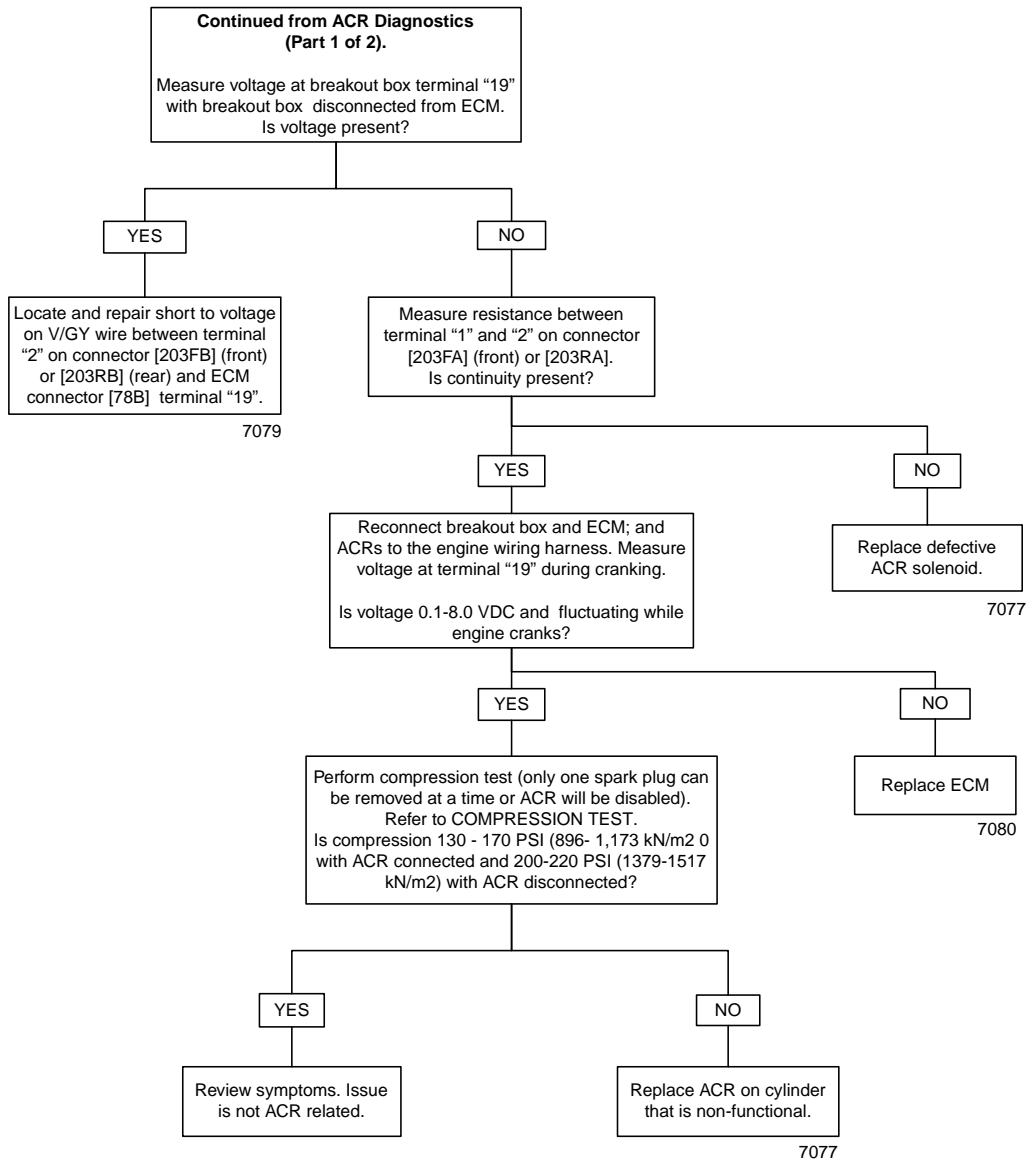

fc01778_en

SUBJECT	PAGE NO.
A.1 CONNECTORS.....	A-1
A.2 INDEX TO WIRING DIAGRAMS.....	A-7

NOTES

CONNECTORS

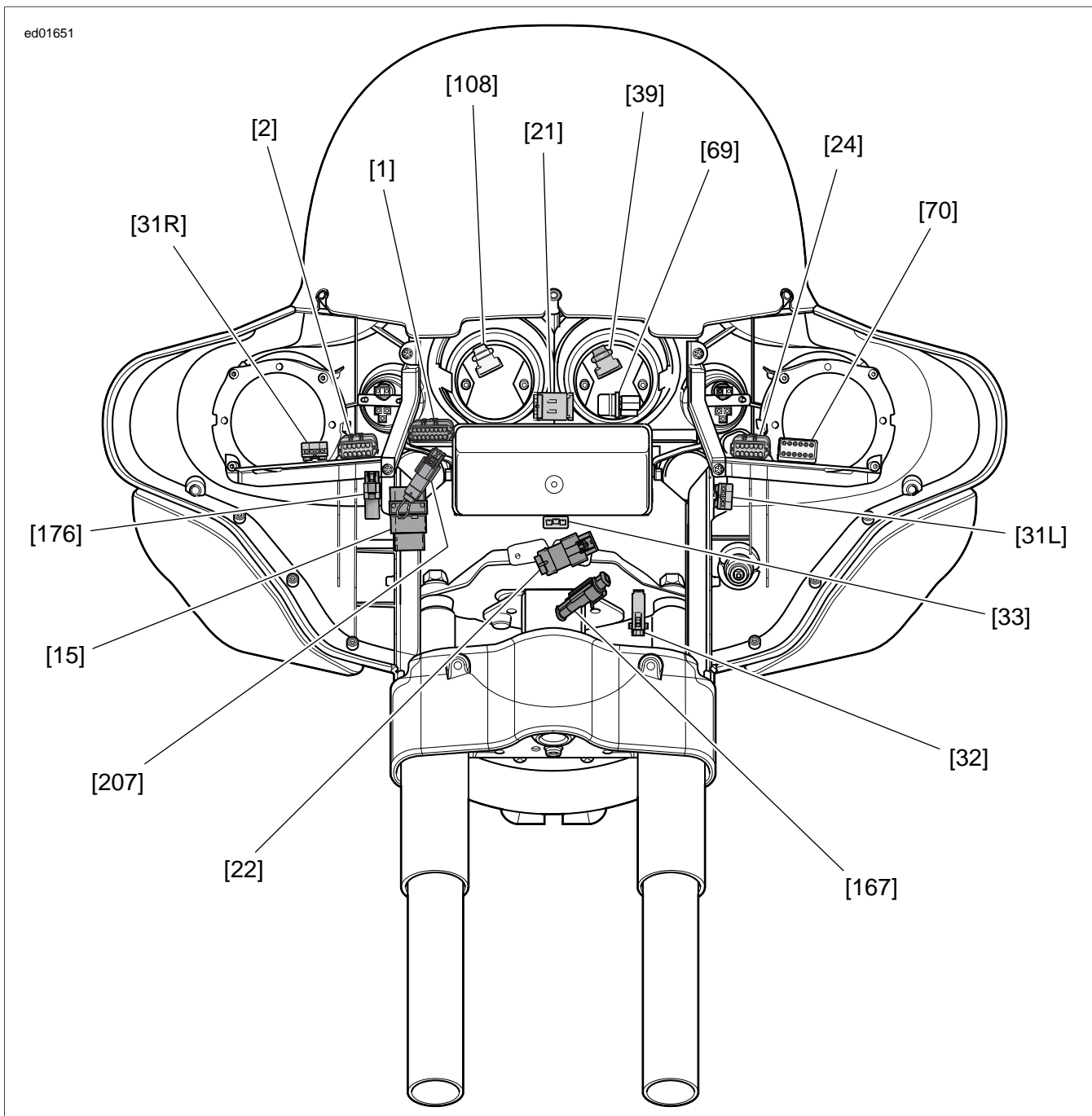

Figure A-1. Inner Fairing

Table A-1. FLHTP Wire Harness Connectors

NO.	DESCRIPTION	TYPE	LOCATION
[1]	Main to interconnect harness	16-place Molex (black)	Inner fairing - right storage box support bracket
[2]	Main to interconnect harness	12-place Molex (gray)	Inner fairing - right fairing support brace
[4]	Accessory	4-place Deutsch	Upper frame cross member (under seat)

Table A-1. FLHTP Wire Harness Connectors

NO.	DESCRIPTION	TYPE	LOCATION
[5]	MAXIFUSE	2-place Packard	Under left side cover
[7]	Rear fender lights harness	8-place Multilock	Top of rear fender (under seat)
[12]	Rear marker lights harness	3-place Multilock	Inboard of left upper frame tube
[13]	Fuel tank harness	4-place Multilock	Behind fuel tank (under seat)
[15]	Main to interconnect harness	4-place Packard	Inner fairing - front of right fairing bracket
[18]	Left rear turn signal	2-place Multilock	Circuit board under tail lamp assembly
[19]	Right rear turn signal	2-place Multilock	Circuit board under tail lamp assembly
[21]	Indicator lights	10-place Multilock	Inner fairing - above storage box
[22]	Interconnect to right handlebar switches	16-place Molex (black)	Inner fairing - fork stem nut lock plate (left side)
[24]	Interconnect to left handlebar switches	12-place Molex (gray)	Inner fairing - left fairing support brace
[30]	TSM/HFSM	12-place Deutsch	Cavity in crossmember at rear of battery box (under seat)
[31L]	Left front turn signal/pursuit lamp	4-place Multilock	Inner fairing - outboard of left fairing bracket
[31R]	Right front turn signal/pursuit lamp	4-place Multilock	Inner fairing - right fairing support brace
[32]	Front fender tip lamp jumper harness	2-place Multilock (black)	Inner fairing - below upper fork bracket (left side)
[33]	Ignition/light key switch	3-place Packard	Inner fairing - under storage box (front of ignition switch housing)
[38]	Headlamp	Headlamp Connector	Inner fairing (back of headlamp)
[39]	Speedometer	12-place Packard (black)	Inner fairing (back of speedometer)
[45]	Rear fender tip lamp	3-place Multilock	Circuit board under tail lamp assembly
[46]	Stator	3-place Lyall	Bottom of voltage regulator (left side)
[57]	Siren/PA speaker	2-place Deutsch	Top rail of engine guard (right side)
[59]	Rear pole lamp	2-place Deutsch	Under luggage rack (left side)
[64]	Fuse block	Packard	Under left side cover
[65]	VSS	3-place Delphi	Top of transmission case (under Starter)
[69]	Pursuit flasher (domestic only)	Relay connector	Inner fairing - front of speedometer
[70]	Siren amplifier harness	12-place Deutsch (black)	Inner fairing - left fairing support brace
[72]	Siren amplifier	18-place Packard	Top rail of saddlebag guard (left side)
[77]	Voltage regulator	2-place Lyall	Bottom of voltage regulator (right side)
[78]	ECM	73-place Packard	Under right side cover
[79]	CKP sensor	2-place Deutsch	Electrical caddy at bottom of lower frame crossmember
[80]	MAP sensor	3-place Packard	Top of induction module
[83]	Ignition coil	4-place Delphi	Below fuel tank (left side)
[84]	Front injector	2-place Delphi	Below fuel tank (left side)
[85]	Rear injector	2-place Delphi	Below fuel tank (left side)
[87]	IAC	4-place Delphi	Below fuel tank (right side)
[88]	TP sensor	3-place Delphi	Below fuel tank (right side)
[89]	IAT sensor	2-place Delphi	Below fuel tank (right side)
[90]	ET sensor	2-place Delphi	Back of front cylinder (left side)
[91]	Data link	4-place Deutsch	Under right side cover
[93]	Tail lamp	4-place Multilock	Circuit board under tail lamp assembly
[94]	Rear fender lights harness to circuit board	6-place Multilock	Circuit board under tail lamp assembly

Table A-1. FLHTP Wire Harness Connectors

NO.	DESCRIPTION	TYPE	LOCATION
[105]	Fairing cap switches	12-place Multilock	Inner fairing - above upper fork bracket (right side)
[108]	Tachometer	12-place Packard (gray)	Inner fairing (back of tachometer)
[110]	Voltmeter lamp	Spade connector	Inner fairing (back of voltmeter)
[111]	Voltmeter	Spade connector	Inner fairing (back of voltmeter)
[116]	Fuel gauge lamp	Spade connector	Inner fairing (back of fuel gauge)
[117]	Fuel gauge	Spade connector	Inner fairing (back of fuel gauge)
[119]	EFI fuses	Fuse terminals	Fuse block (under right side cover)
[121]	Rear brake light switch	Spade terminals	Bottom of rear frame downtube (right side)
[122]	Horn	Spade terminals	Between cylinders (left side)
[123]	Starter relay	Relay connector	Fuse block (under left side cover)
[124]	Brake light relay	Relay connector	Fuse block (under left side cover)
[126]	Ignition keyswitch relay	Relay connector	Cavity in crossmember at rear of battery box (under seat)
[128]	Starter solenoid	Spade terminals	Top of starter
[129]	Harness grounds	Ring terminals	Upper frame cross member (under seat)
[131]	Neutral switch	Post terminals	Top of transmission (right side)
[132]	Cigarette lighter	Spade terminals	Inner fairing (left side)
[133]	Jiffy Stand Sensor	3-place Molex (black)	HDI: Electrical caddie at bottom of lower frame crossmember. (Not used on Domestic)
[135]	EFI system relay	Relay connector	Fuse block (under right side cover)
[137]	O2 sensor rear exhaust header	2-place Amp (Tyco)	Under chrome starter cover
[138]	O2 sensor front exhaust header	2-place Amp (Tyco)	Back of cross brace between front frame downtubes (left side)
[139]	Oil pressure sender	4-place Delphi	Front right crankcase
[141]	Fuel level sender and fuel pump	4-place Packard	Top of canopy (under console)
[156]	Main to interconnect harness	6-place Deutsch	Inner fairing - right fairing support brace
[160]	B+	1-place Packard	Upper frame cross member (under seat)
[166]	ABS module	20-place Molex	Under right side cover
[167]	Front wheel speed sensor	2-place Amp (Tyco)	Inner fairing - below upper fork bracket (left side)
[168]	Rear wheel speed sensor	2-place Amp (Tyco)	Under right side cover
[176]	Main to interconnect harness	6-place Deutsch	Inner fairing - outboard of right fairing bracket
[178]	Active intake solenoid	2-place Amp (Tyco)	Back of air cleaner backplate
[179]	Active exhaust actuator	5-place Amp (Tyco)	Domestic (not used): under right side cover HDI: under right side cover (behind electrical bracket)
[201]	ABS diode pack	4-place Deutsch	Under right side cover
[203F]	ACR solenoid	2-place Amp (Tyco)	Between cylinders
[203R]	ACR solenoid	2-place Amp (Tyco)	Between cylinders
[204]	Twist Grip sensor	6-place Molex	Inner fairing, right support bracket
[207]	Stealth (disable lighting circuit)	3-place Molex (black)	Inner fairing - front of right fairing bracket
[211]	Throttle Control Actuator	6-place Molex	Throttle body

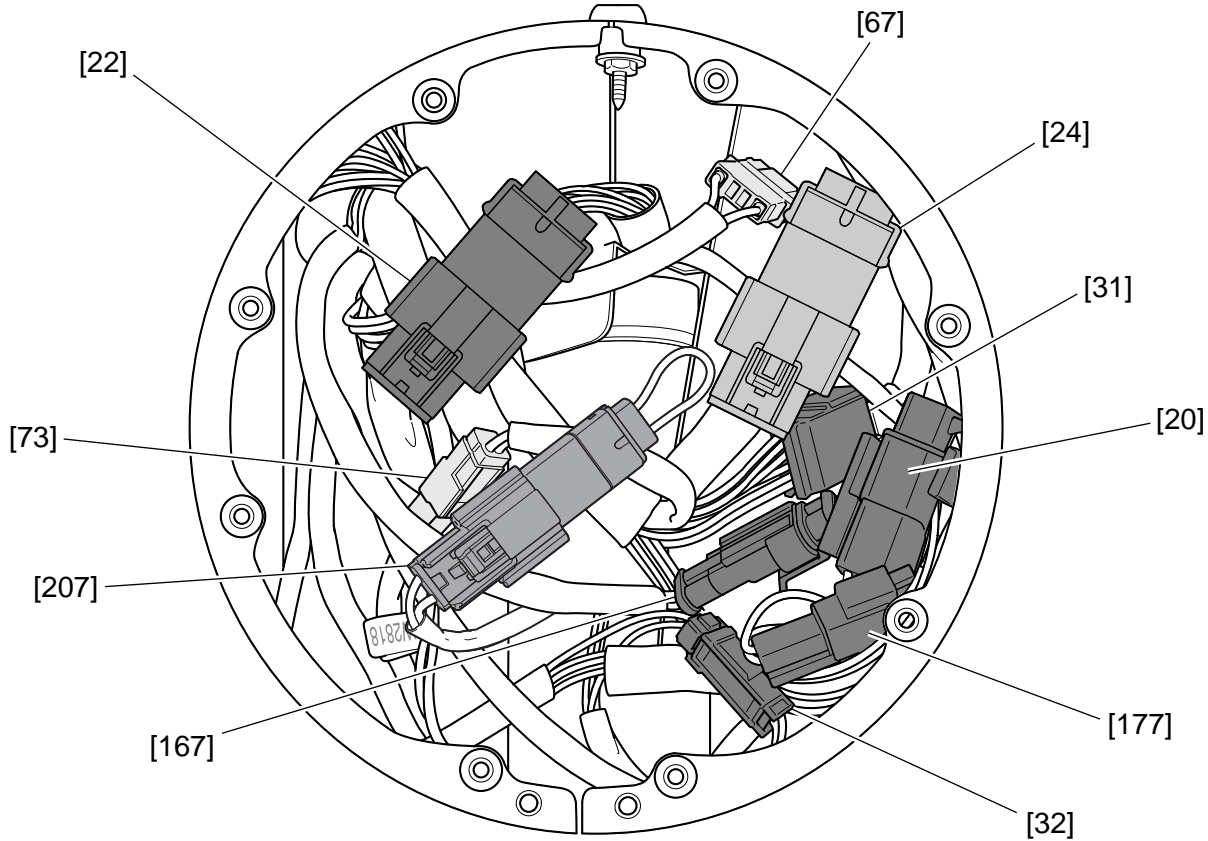

Figure A-2. Headlamp Nacelle (FLHP/E)

Table A-2. FLHP/E Wire Harness Connectors

NO.	DESCRIPTION	TYPE	LOCATION
[4]	Accessory	4-place Deutsch	Upper frame cross member (under seat)
[5]	MAXIFUSE	2-place Packard	Under left side cover
[7]	Rear fender lights harness	8-place Multilock	Top of rear Fender (under seat)
[18]	Left rear turn signal	2-place Multilock	Circuit board under tail lamp assembly
[19]	Right rear turn signal	2-place Multilock	Circuit board under tail lamp assembly
[20]	Tachometer harness	6-place Deutsch	Inside headlamp nacelle
[21]	Indicator lamps	8-place Deutsch	Under console
[22]	Right handlebar switches	12-place Molex	Inside headlamp nacelle - fork stem nut lock plate (right side)
[24]	Left handlebar switches	12-place Molex	Inside headlamp nacelle - fork stem nut lock plate (left side)
[30]	TSM/HFSM	12-place Deutsch	Cavity in crossmember at rear of battery box (under seat)
[31]	Front turn signals	6-place Multilock	Inside headlamp nacelle - fork stem nut lock plate (left side)
[32]	Front fender tip lamp jumper harness	2-place Multilock (black)	Inside headlamp nacelle
[33]	Ignition/light key switch	3-place Packard	Under console
[38]	Headlamp	Headlamp connector	Inside headlamp nacelle
[39]	Speedometer	12-place Packard	Back of speedometer (under console)

Table A-2. FLHP/E Wire Harness Connectors

NO.	DESCRIPTION	TYPE	LOCATION
[45]	Rear fender tip lamp	3-place Multilock	Circuit board under tail lamp assembly
[46]	Stator	3-place Lyall	Bottom of voltage regulator (left side)
[57]	Siren/PA speaker	2-place Deutsch	Top rail of engine guard (right side)
[59]	Rear pole lamp	2-place Deutsch	Under luggage rack (left side)
[64]	Fuse block	Packard	Under left side cover
[65]	VSS	3-place Delphi	Top of transmission case (under Starter)
[67]	Accessory switch	4-place Amp	Inside headlamp nacelle
[69]	Pursuit flasher (domestic only)	Relay connector	Inside headlamp nacelle
[72]	Siren amplifier	18-place Packard	Top rail of saddlebag guard (left side)
[73]	Pursuit lamps	2-place Multilock (white)	Inside headlamp nacelle
[77]	Voltage regulator	2-place Lyall	Bottom of voltage regulator (right side)
[78]	ECM	73-place Packard	Under right side cover
[79]	CKP sensor	2-place Deutsch	Electrical caddy at bottom of lower frame crossmember
[80]	MAP sensor	3-place Packard	Top of induction module
[83]	Ignition coil	4-place Delphi	Below fuel tank (left side)
[84]	Front injector	2-place Delphi	Below fuel tank (left side)
[85]	Rear injector	2-place Delphi	Below fuel tank (left side)
[87]	IAC	4-place Delphi	Below fuel tank (right side)
[88]	TP sensor	3-place Delphi	Below fuel tank (right side)
[89]	IAT sensor	2-place Delphi	Below fuel tank (right side)
[90]	ET sensor	2-place Delphi	Back of Front Cylinder (left side)
[91]	Data link	4-place Deutsch	Under right side cover
[93]	Tail lamp	4-place Multilock	Circuit board under tail lamp assembly
[94]	Rear fender lights harness to circuit board	6-place Multilock	Circuit board under tail lamp assembly
[108]	Tachometer	12-place Packard (gray)	Back of tachometer
[117]	Fuel gauge	4-place Multilock	Below fuel tank (left side)
[119]	EFI fuses	Fuse terminals	Fuse block (under right side cover)
[120]	Oil pressure switch	Post terminal	Front Right Crankcase
[121]	Rear brake light switch	Spade terminals	Bottom of rear frame downtube (right side)
[122]	Horn	Spade terminals	Between cylinders (left side)
[123]	Starter relay	Relay connector	Fuse Block (under left side cover)
[124]	Brake light relay	Relay connector	Fuse Block (under left side cover)
[126]	Ignition keyswitch relay	Relay connector	Cavity in crossmember at rear of battery box (under seat)
[128]	Starter solenoid	Spade terminals	Top of starter
[129]	Harness grounds	Ring terminals	Upper frame cross member (under seat)
[131]	Neutral switch	Post terminals	Top of transmission (right side)
[133]	Jiffy Stand Sensor	3-place Molex (black)	HDI: Electrical caddy at bottom of lower frame crossmember. (Not used on Domestic)
[135]	EFI system relay	Relay connector	Fuse block (under right side cover)
[137]	O2 sensor rear exhaust header	2-place Amp (Tyco)	Under chrome starter cover
[138]	O2 sensor front exhaust header	2-place Amp (Tyco)	Back of cross brace between front frame downtubes (left side)
[141]	Fuel level sender and fuel pump	4-place Packard	Top of canopy (under console)

Table A-2. FLHP/E Wire Harness Connectors

NO.	DESCRIPTION	TYPE	LOCATION
[143]	Front fender tip lamp (DOM)	2-place Multilock (black)	Under front fender tip lamp bracket
[160]	B+	1-place Packard	Upper frame cross member (under seat)
[166]	ABS module	20-place Molex	Under right side cover
[167]	Front wheel speed sensor	2-place Amp (Tyco)	Inside headlamp nacelle (left side)
[168]	Rear wheel speed sensor	2-place Amp (Tyco)	Under right side cover
[173]	Rear marker lights harness	3-place Multilock	Inboard of left upper frame tube
[176]	Main to main harness	4-place Deutsch	Under left side cover (beneath harness)
[178]	Active intake solenoid	2-place Amp (Tyco)	Back of air cleaner backplate
[179]	Active exhaust actuator	5-place Amp (Tyco)	Domestic (not used): under right side cover HDI: under right side cover (behind electrical bracket)
[177]	Main to main harness	2-place Deutsch	Inside headlamp nacelle (left side)
[201]	ABS diode pack	4-place Deutsch	Under right side cover
[203F]	ACR solenoid	2-place Amp (Tyco)	Between cylinders
[203R]	ACR solenoid	2-place Amp (Tyco)	Between cylinders
[204]	Twist Grip sensor	6-place Molex	Inside Headlamp Nacelle
[207]	Stealth (disable lighting circuit)	3-place Molex	Inside headlamp nacelle
[211]	Throttle Control Actuator	6-place Molex	Throttle body
[222]	Ignition switch interconnect	4-place Packard	Under the seat

WIRING DIAGRAM INFORMATION

Wire Color Codes

Wire traces on wiring diagrams are labeled with alpha codes. Refer to [Table A-3](#).

For Solid Color Wires: See [Figure A-3](#). The alpha code identifies wire color (3).

For Striped Wires: The code is written with a slash (/) between the solid color code and the stripe code (4). For example, a trace labeled GN / Y is a green wire with a yellow stripe.

Wiring Diagram Symbols

See [Figure A-3](#). On wiring diagrams and in service/repair instructions, connectors are identified by a number in brackets (1). The letter (2) inside the brackets identifies whether the housing is a socket or pin housing.

A=Pin: The letter A after a connector number and the pin symbol (6) identifies a pin housing.

B=Socket: The letter B after a connector number and the socket symbol (5) identifies a socket housing.

Other symbols found on the wiring diagrams include the symbol for a diode (7), a symbol for a wire-to-wire connection (8), a symbol that verifies that no connection (9) between two wire traces exists and a symbol identifying two wires that are twisted together (10).

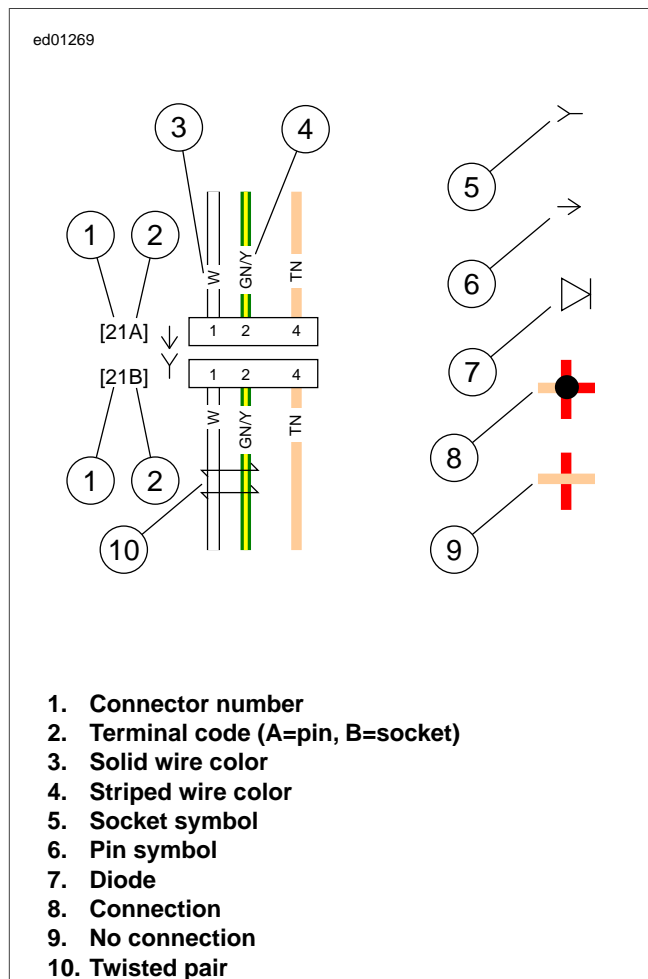

Figure A-3. Connector/Wiring Diagram Symbols (typical)

Table A-3. Wire Color Codes

ALPHA CODE	WIRE COLOR
BE	Blue
BK	Black
BN	Brown
GN	Green
GY	Grey
LGN	Light Green
O	Orange
PK	Pink
R	Red
TN	Tan
V	Violet
W	White
Y	Yellow

Wiring Diagram List

DIAGRAM	LOCATION
2008 FLHTP, DOMESTIC and INTERNATIONAL Models, Main Harness without ABS (1 of 2)	Figure A-4
2008 FLHTP, DOMESTIC and INTERNATIONAL Models, Main Harness with ABS (1 of 2)	Figure A-5
2008 FLHTP, DOMESTIC and INTERNATIONAL Models, Main Harness (2 of 2)	Figure A-6
2008 FLHTP, DOMESTIC and INTERNATIONAL Models, Interconnect Harness	Figure A-7
2008 FLHTP, DOMESTIC and INTERNATIONAL Models, Pursuit Lamps, Directional Lamps, Tail Lamp and Fender Tip Lamps	Figure A-8
2008 FLHTP, DOMESTIC and INTERNATIONAL Models, Starting and Charging	Figure A-9
2008 FLHTP, DOMESTIC and INTERNATIONAL Models, Handlebar Switches, Indicator Lamps, Fairing Cap Switches and HFSM Antenna	Figure A-10
2008 FLHTP, DOMESTIC and INTERNATIONAL Models, Anti-Lock Brake System (ABS) Siren Amplifier and Strobe Harness	Figure A-11
2008 FLHP and FLHPE, DOMESTIC and INTERNATIONAL Models, Main Harness without ABS (1 of 2)	Figure A-12
2008 FLHP and FLHPE, DOMESTIC and INTERNATIONAL Models, Main Harness with ABS (1 of 2)	Figure A-13
2008 FLHP and FLHPE, DOMESTIC and INTERNATIONAL Models, Main Harness (2 of 2)	Figure A-14
2008 FLHP and FLHPE, DOMESTIC and INTERNATIONAL Models, Starting and Charging	Figure A-15
2008 FLHP and FLHPE, DOMESTIC and INTERNATIONAL Models, Handlebar Switches, Indicator Lamps, Tail Lamp, Pursuit Lamps, Directional Lamps, Accessory/Spot Switch, Speedometer, Tachometer and HFSM Antenna	Figure A-16
2008 FLHTP, FLHP and FLHPE, DOMESTIC and INTERNATIONAL Models, Optional Strobe System	Figure A-17

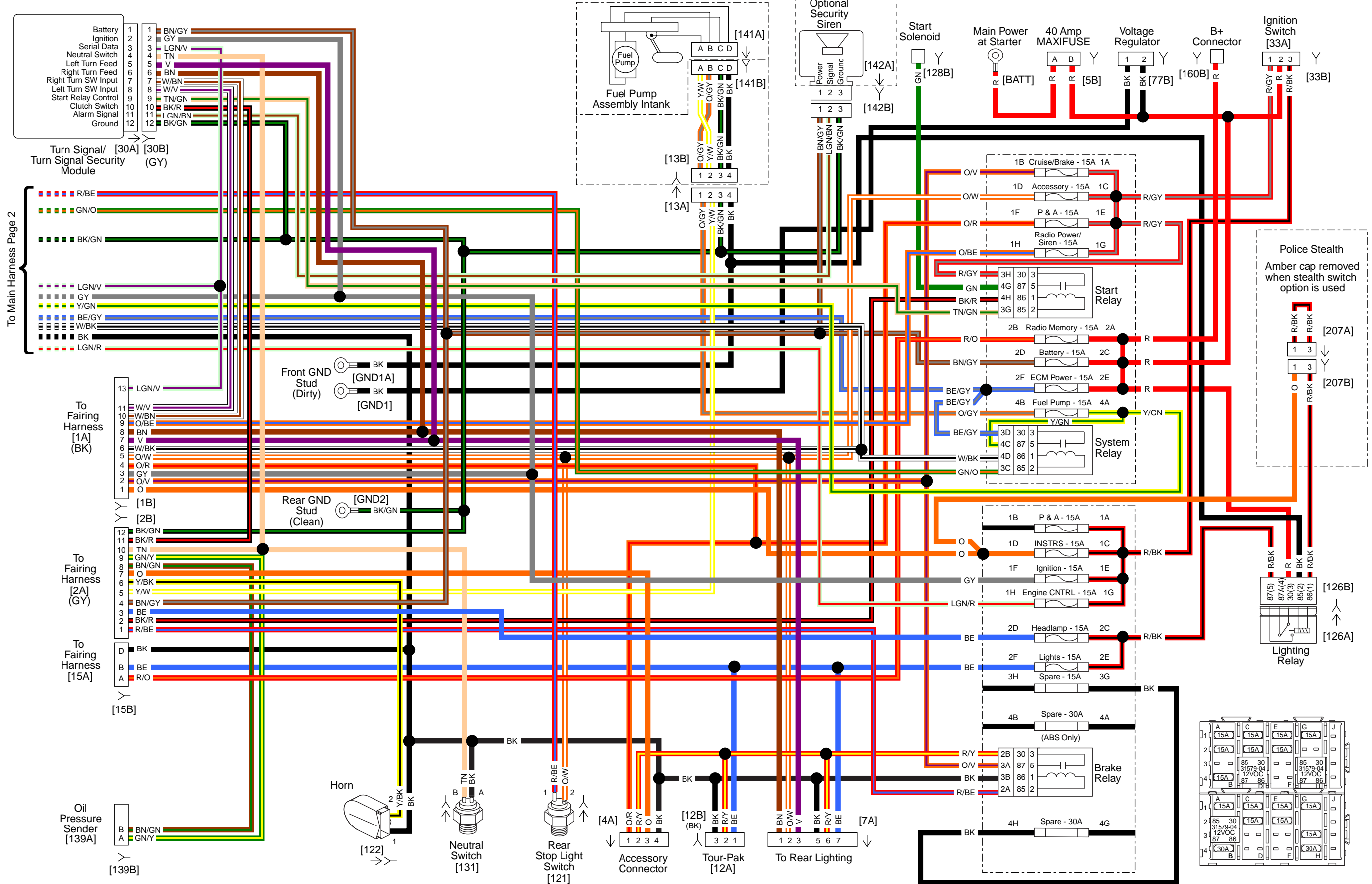

Figure A-4. 2008 FLHTP, DOMESTIC and INTERNATIONAL Models, Main Harness without ABS (1 of 2)

Figure A-4.
2008 FLHTP, DOMESTIC and INTERNATIONAL Models, Main
Harness without ABS (1 of 2)

Figure A-4.
2008 FLHTP, DOMESTIC and INTERNATIONAL Models, Main
Harness without ABS (1 of 2)

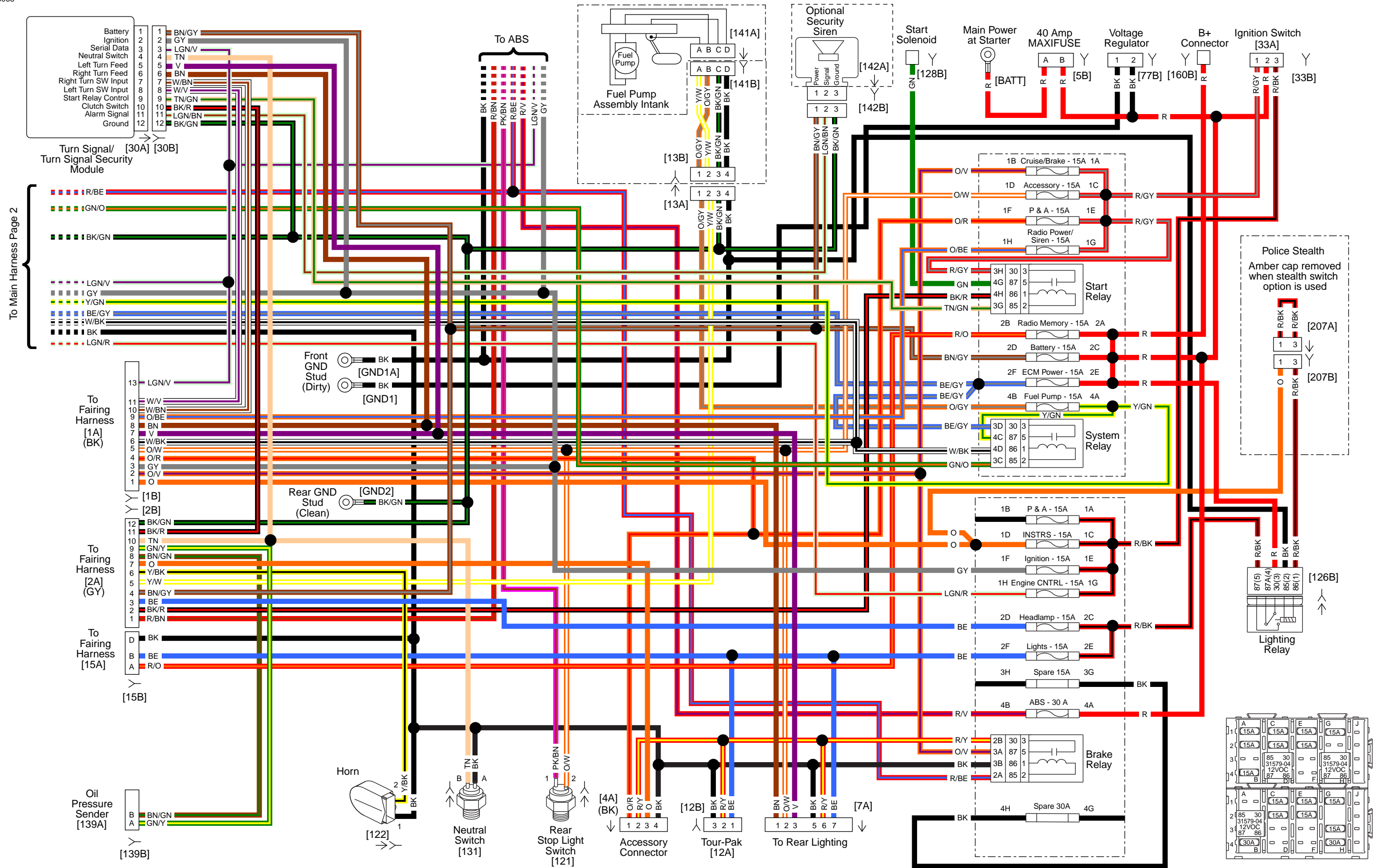

Figure A-5. 2008 FLHTP, DOMESTIC and INTERNATIONAL Models, Main Harness with ABS (1 of 2)

Figure A-5.
2008 FLHTP, DOMESTIC and INTERNATIONAL Models, Main
Harness with ABS (1 of 2)

Figure A-5.
2008 FLHTP, DOMESTIC and INTERNATIONAL Models, Main
Harness with ABS (1 of 2)

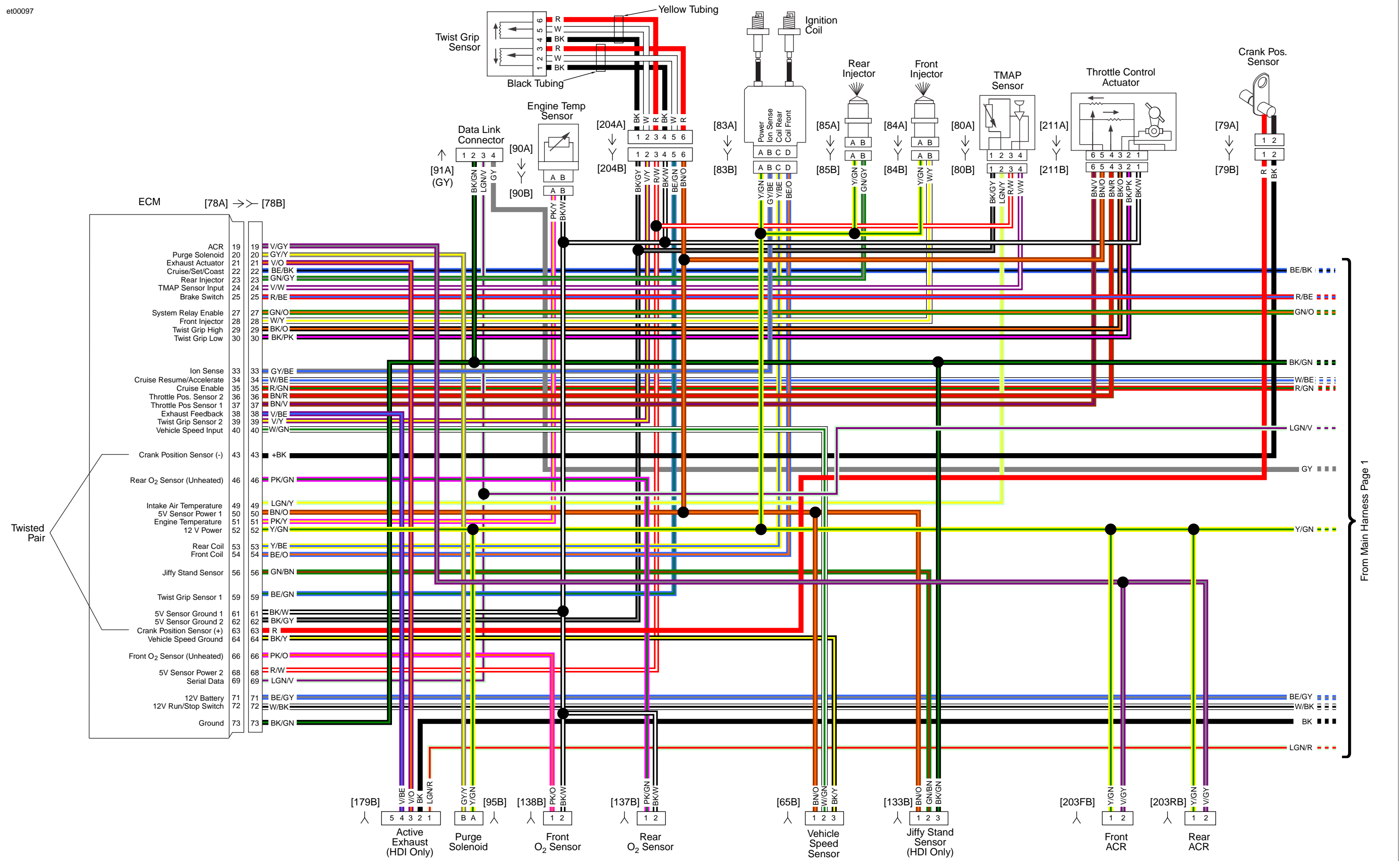

Figure A-6. 2008 FLHTP, DOMESTIC and INTERNATIONAL Models, Main Harness (2 of 2)

Figure A-6.
2008 FLHTP, DOMESTIC and INTERNATIONAL Models, Main
Harness (2 of 2)

Figure A-6.
2008 FLHTP, DOMESTIC and INTERNATIONAL Models, Main
Harness (2 of 2)

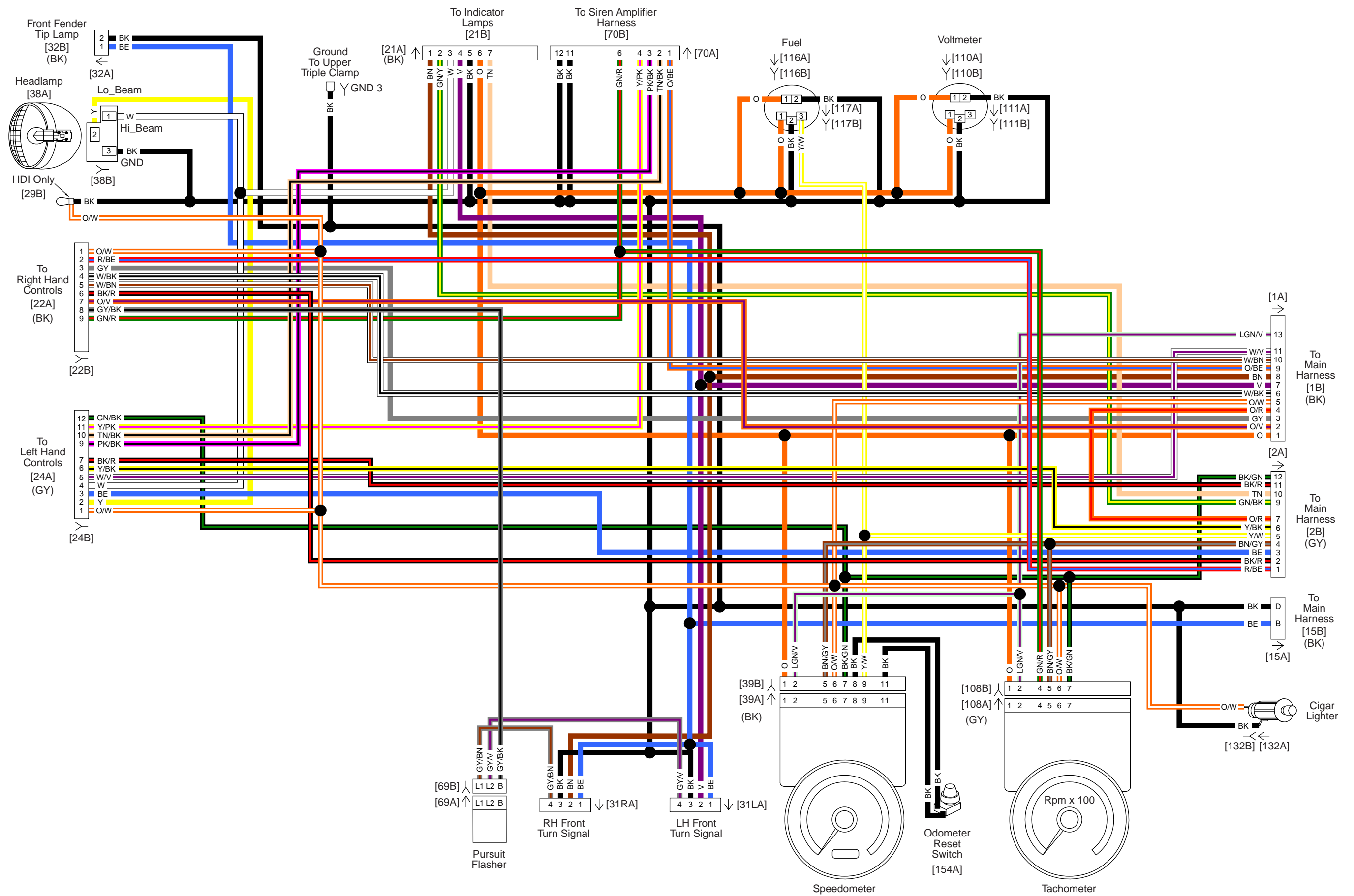

Figure A-7. 2008 FLHTP, DOMESTIC and INTERNATIONAL Models, Interconnect Harness

Figure A-7.
2008 FLHTTP, DOMESTIC and INTERNATIONAL Models,
Interconnect Harness

Figure A-7.
2008 FLHTTP, DOMESTIC and INTERNATIONAL Models,
Interconnect Harness

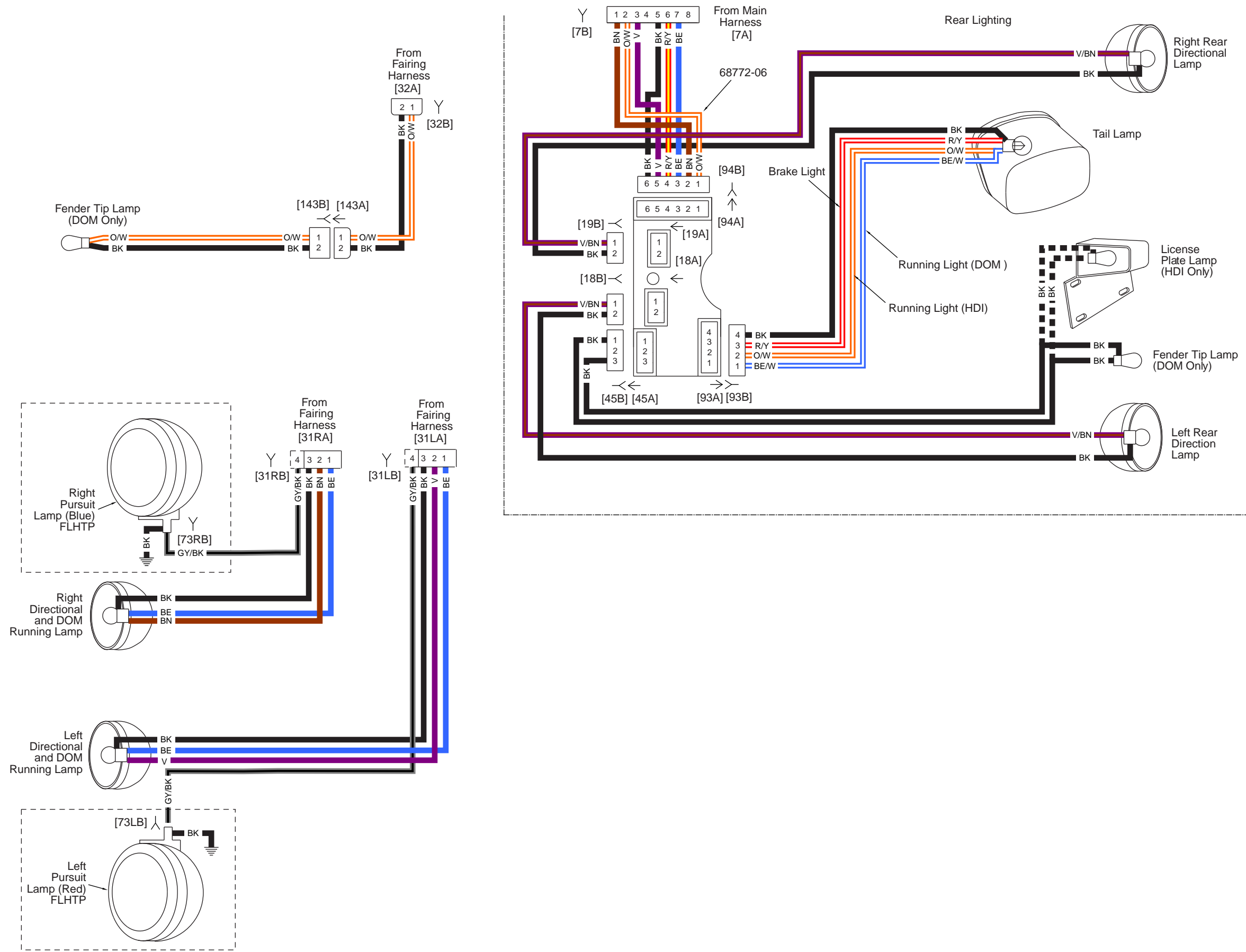

Figure A-8. 2008 FLHTP, DOMESTIC and INTERNATIONAL Models, Pursuit Lamps, Directional Lamps, Tail Lamp and Fender Tip Lamps

Figure A-8.

**2008 FLHTP, DOMESTIC and INTERNATIONAL Models, Pursuit
Lamps, Directional Lamps, Tail Lamp and Fender Tip Lamps**

Figure A-8.

**2008 FLHTP, DOMESTIC and INTERNATIONAL Models, Pursuit
Lamps, Directional Lamps, Tail Lamp and Fender Tip Lamps**

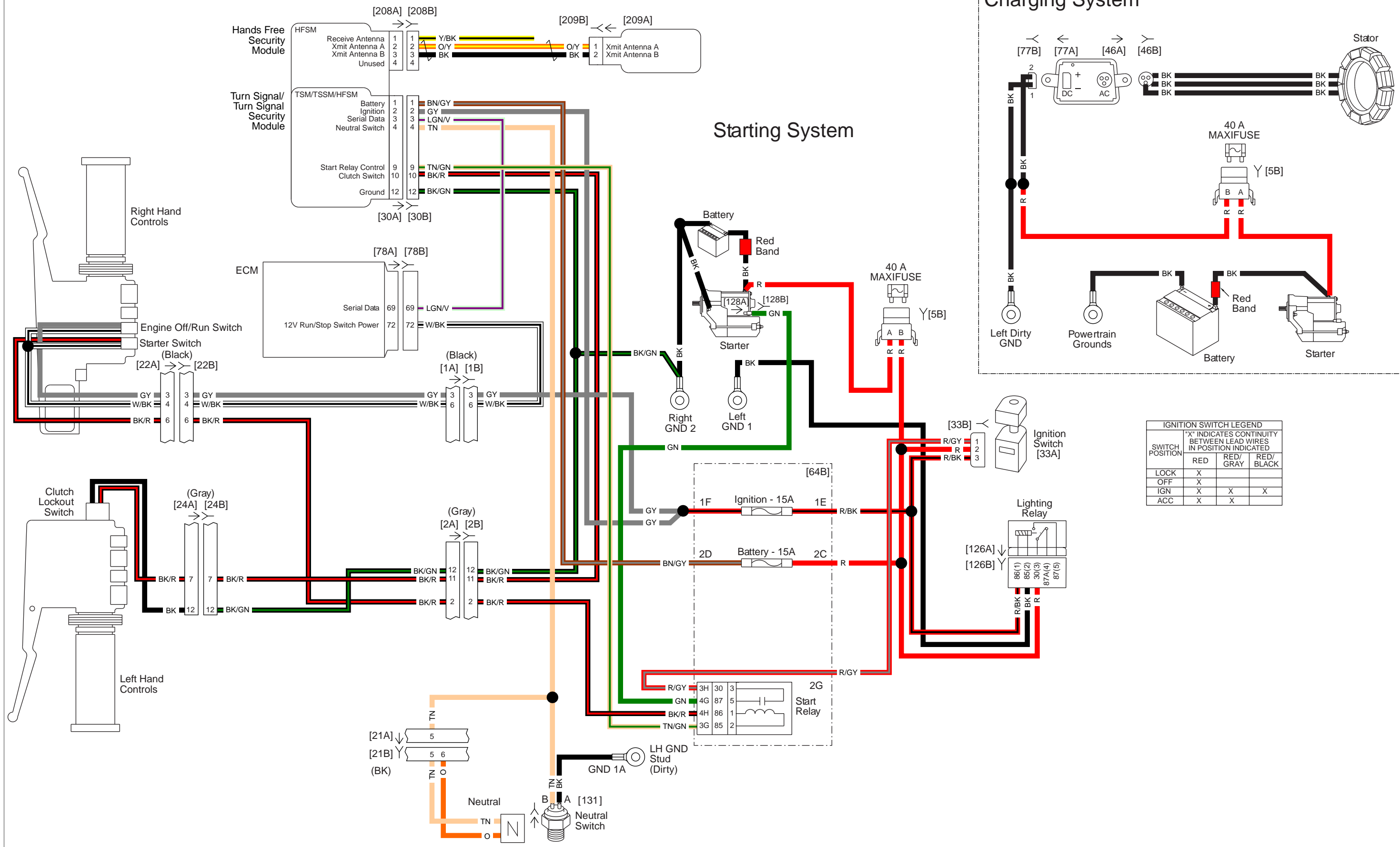

Figure A-9. 2008 FLHTP, DOMESTIC and INTERNATIONAL Models, Starting and Charging

Figure A-9.
2008 FLHTP, DOMESTIC and INTERNATIONAL Models, Starting
and Charging

Figure A-9.
2008 FLHTP, DOMESTIC and INTERNATIONAL Models, Starting
and Charging

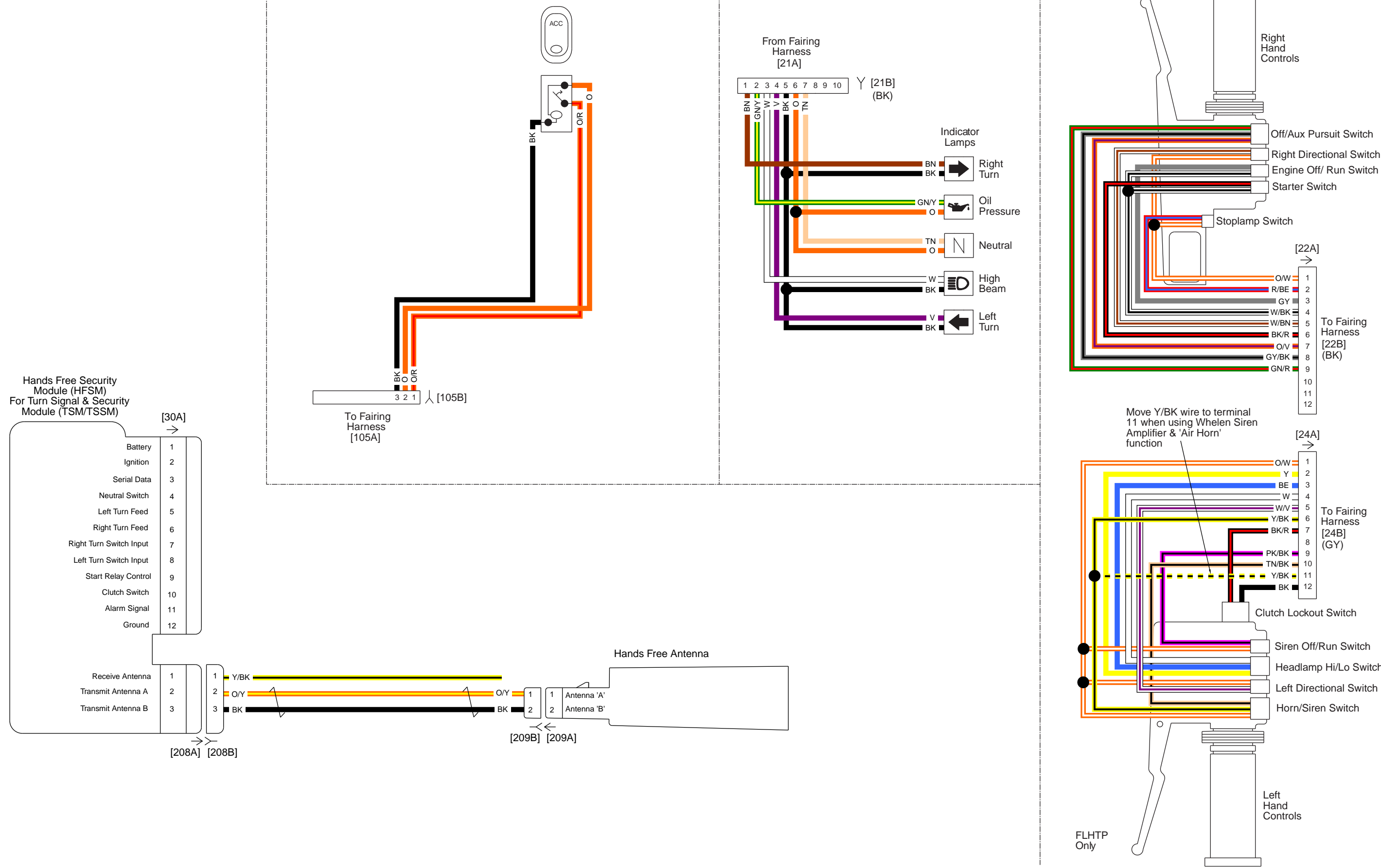

Figure A-10. 2008 FLHTP, DOMESTIC and INTERNATIONAL Models, Handlebar Switches, Indicator Lamps, Fairing Cap Switches and HFSM Antenna

Figure A-10.

**2008 FLHTP, DOMESTIC and INTERNATIONAL Models,
Handlebar Switches, Indicator Lamps, Fairing Cap Switches and
HFSM Antenna**

Figure A-10.

**2008 FLHTP, DOMESTIC and INTERNATIONAL Models,
Handlebar Switches, Indicator Lamps, Fairing Cap Switches and
HFSM Antenna**

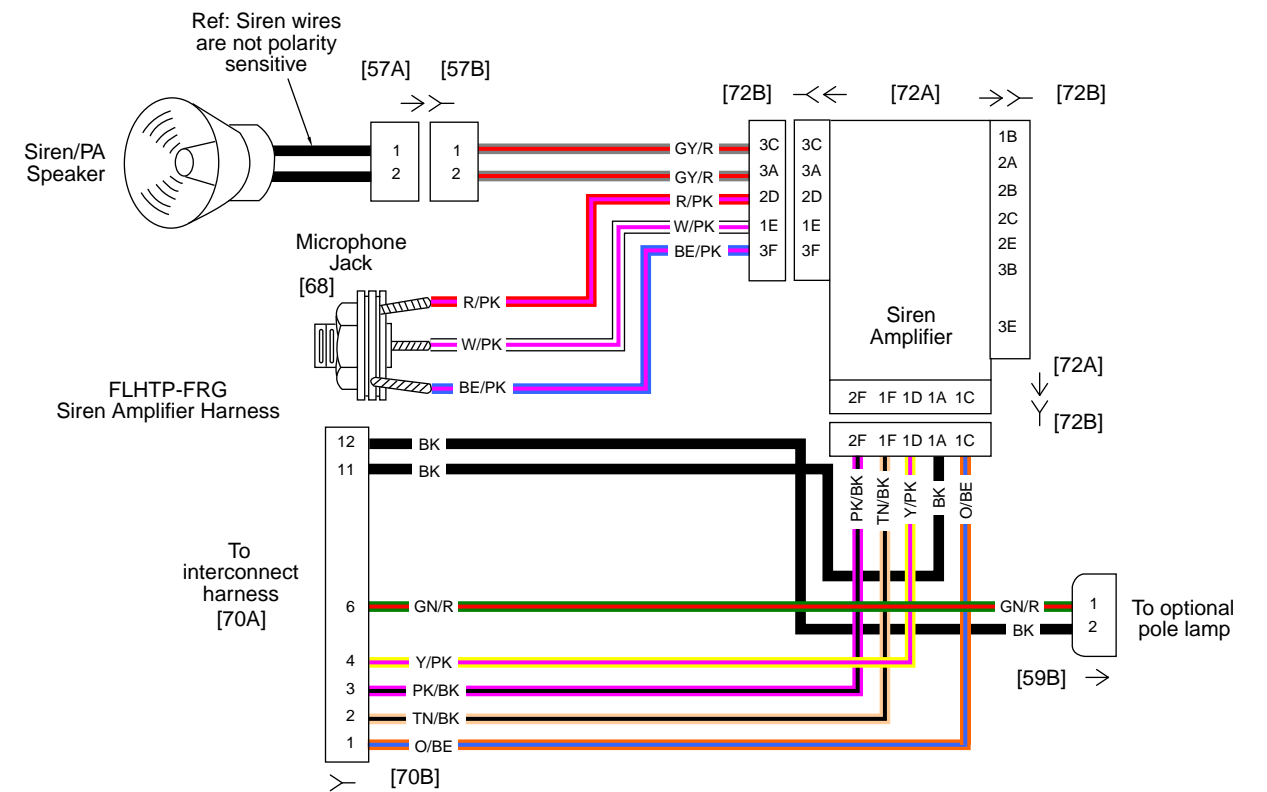
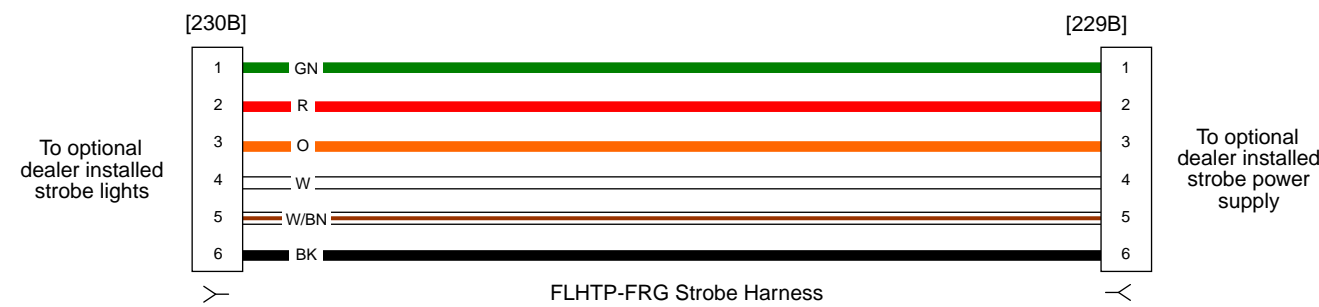
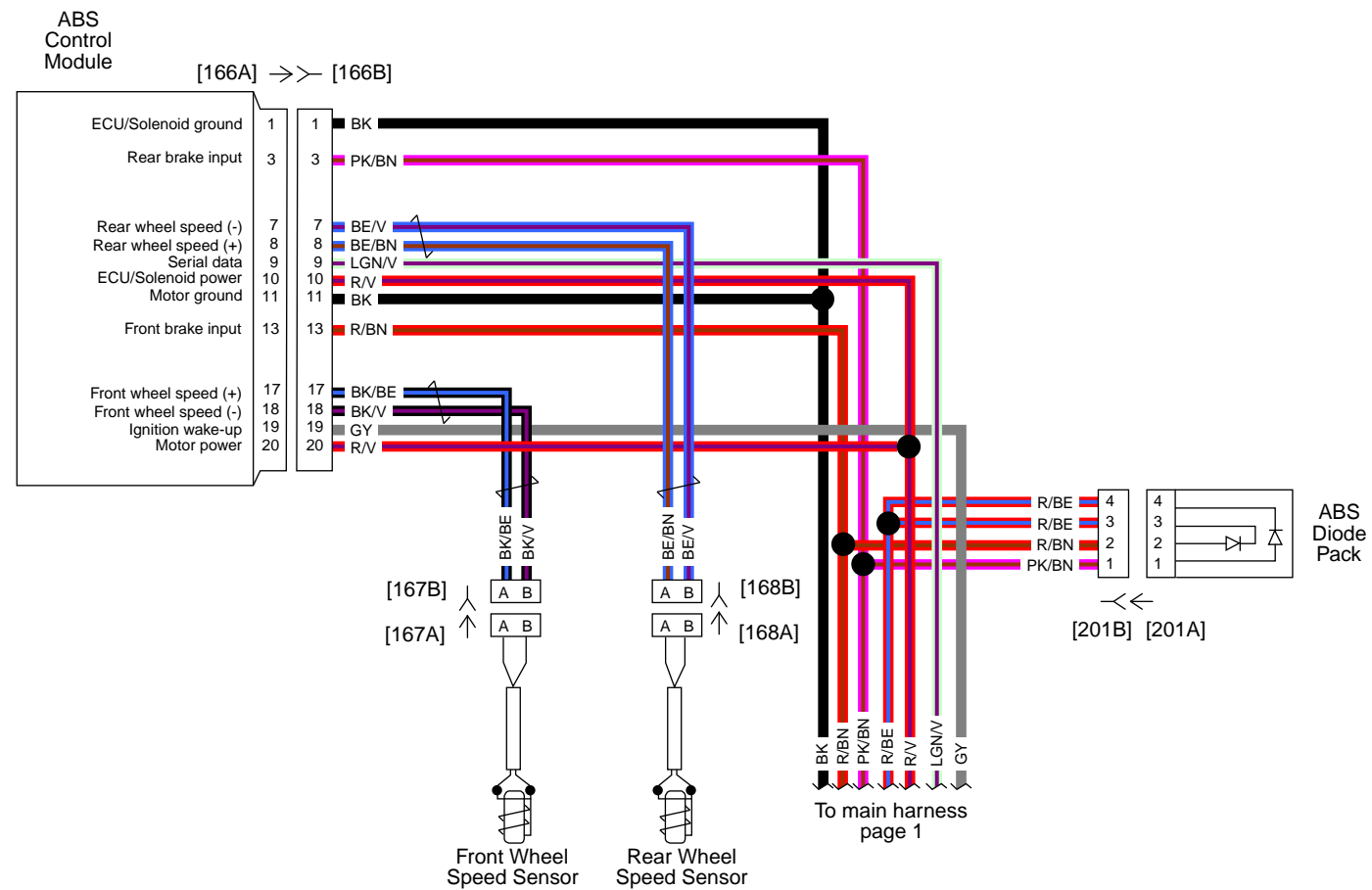

Figure A-11. 2008 FLHTP, DOMESTIC and INTERNATIONAL Models, Anti-Lock Brake System (ABS) Siren Amplifier and Strobe Harness

Figure A-11.

**2008 FLHTP, DOMESTIC and INTERNATIONAL Models, Anti-Lock
Brake System (ABS) Siren Amplifier and Strobe Harness**

Figure A-11.

**2008 FLHTP, DOMESTIC and INTERNATIONAL Models, Anti-Lock
Brake System (ABS) Siren Amplifier and Strobe Harness**

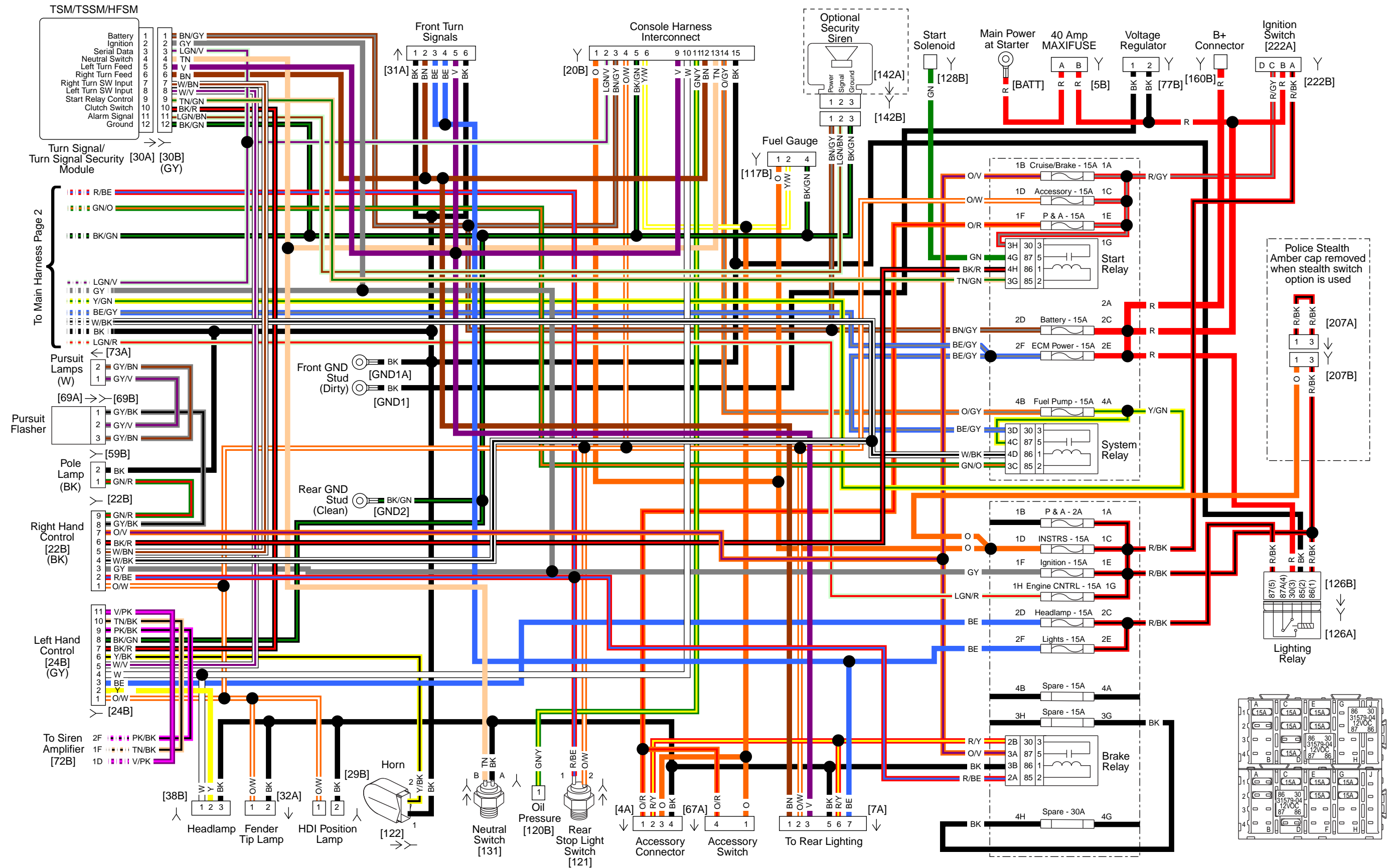

Figure A-12. 2008 FLHP and FLHPE, DOMESTIC and INTERNATIONAL Models, Main Harness without ABS (1 of 2)

Figure A-12.

**2008 FLHP and FLHPE, DOMESTIC and INTERNATIONAL Models,
Main Harness without ABS (1 of 2)**

Figure A-12.

**2008 FLHP and FLHPE, DOMESTIC and INTERNATIONAL Models,
Main Harness without ABS (1 of 2)**

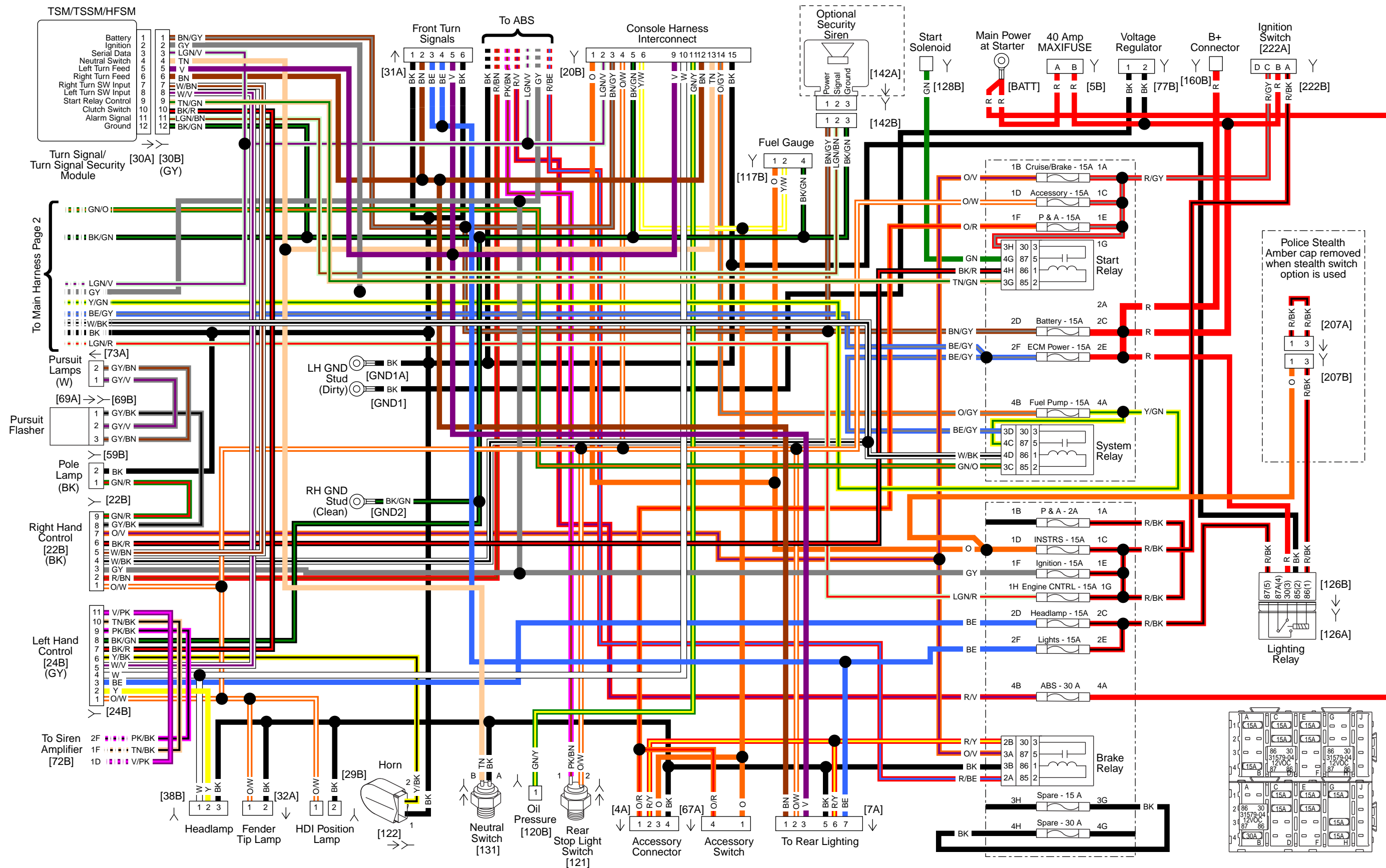

Figure A-13. 2008 FLHP and FLPE, DOMESTIC and INTERNATIONAL Models, Main Harness with ABS (1 of 2)

Figure A-13.

**2008 FLHP and FLHPE, DOMESTIC and INTERNATIONAL Models,
Main Harness with ABS (1 of 2)**

Figure A-13.

**2008 FLHP and FLHPE, DOMESTIC and INTERNATIONAL Models,
Main Harness with ABS (1 of 2)**

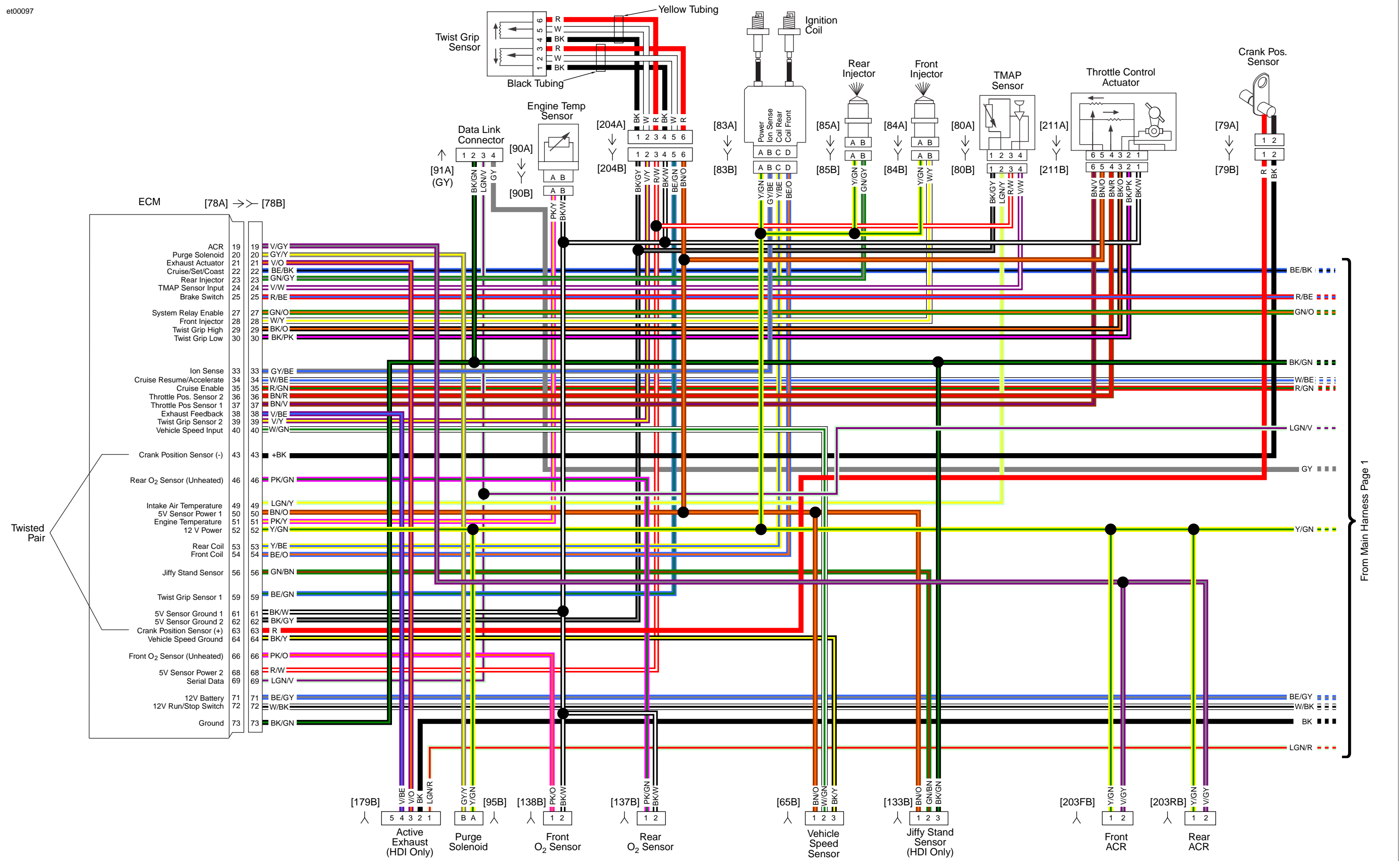

Figure A-14. 2008 FLHP and FLPE, DOMESTIC and INTERNATIONAL Models, Main Harness (2 of 2)

From Main Harness Page 1

Figure A-14.
2008 FLHP and FLHPE, DOMESTIC and INTERNATIONAL Models,
Main Harness (2 of 2)

Figure A-14.
2008 FLHP and FLHPE, DOMESTIC and INTERNATIONAL Models,
Main Harness (2 of 2)

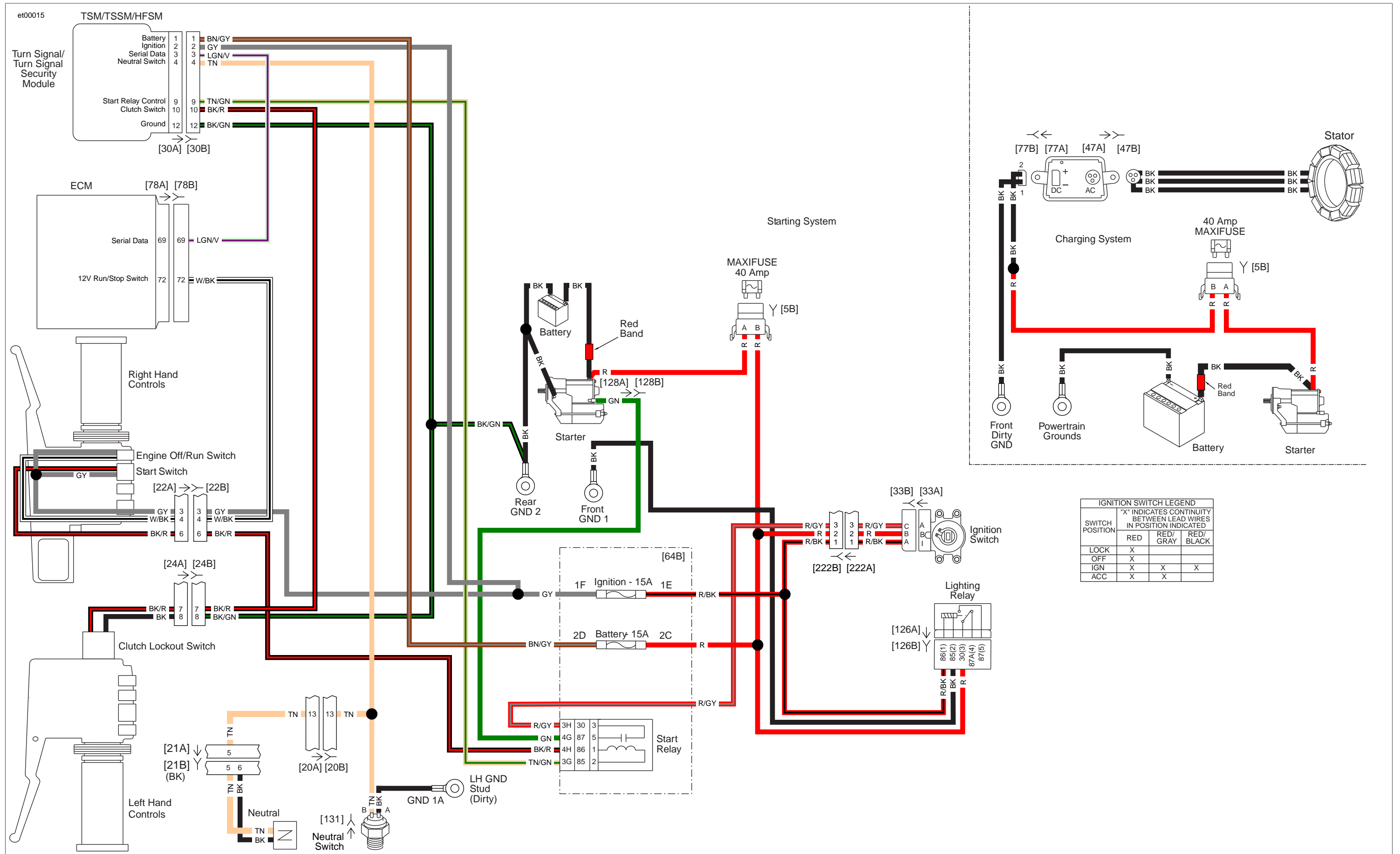

Figure A-15. 2008 FLHP and FLPE, DOMESTIC and INTERNATIONAL Models, Starting and Charging

Figure A-15.
2008 FLHP and FLHPE, DOMESTIC and INTERNATIONAL Models,
Starting and Charging

Figure A-15.
2008 FLHP and FLHPE, DOMESTIC and INTERNATIONAL Models,
Starting and Charging

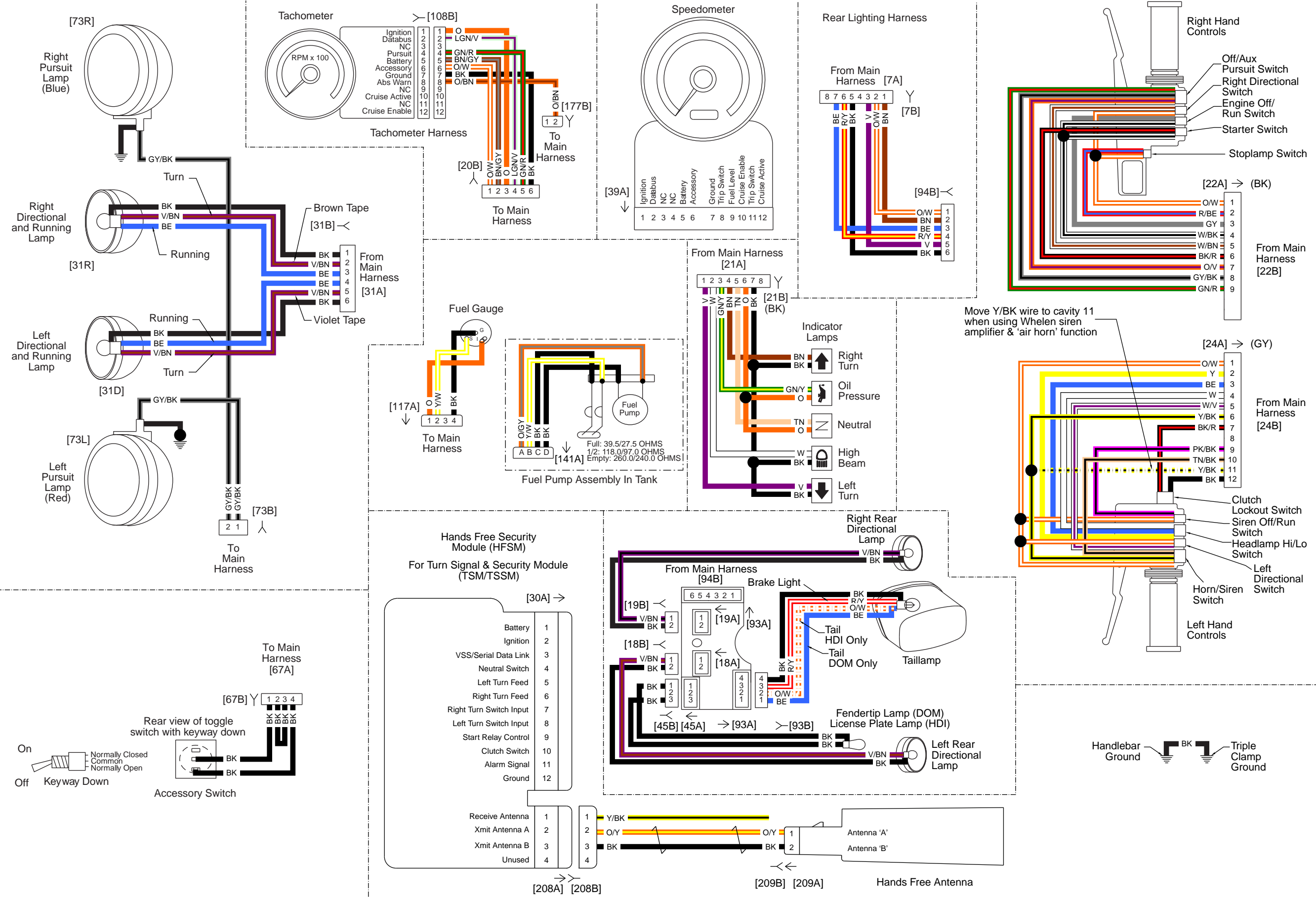

Figure A-16. 2008 FLHP and FLHPE, DOMESTIC and INTERNATIONAL Models, Handlebar Switches, Indicator Lamps, Tail Lamp, Pursuit Lamps, Directional Lamps, Accessory/Spot Switch, Speedometer, Tachometer and HFSM Antenna

Figure A-16.

**2008 FLHP and FLHPE, DOMESTIC and INTERNATIONAL Models,
Handlebar Switches, Indicator Lamps, Tail Lamp, Pursuit Lamps,
Directional Lamps, Accessory/Spot Switch, Speedometer,
Tachometer and HFSSM Antenna**

Figure A-16.

**2008 FLHP and FLHPE, DOMESTIC and INTERNATIONAL Models,
Handlebar Switches, Indicator Lamps, Tail Lamp, Pursuit Lamps,
Directional Lamps, Accessory/Spot Switch, Speedometer,
Tachometer and HFSSM Antenna**

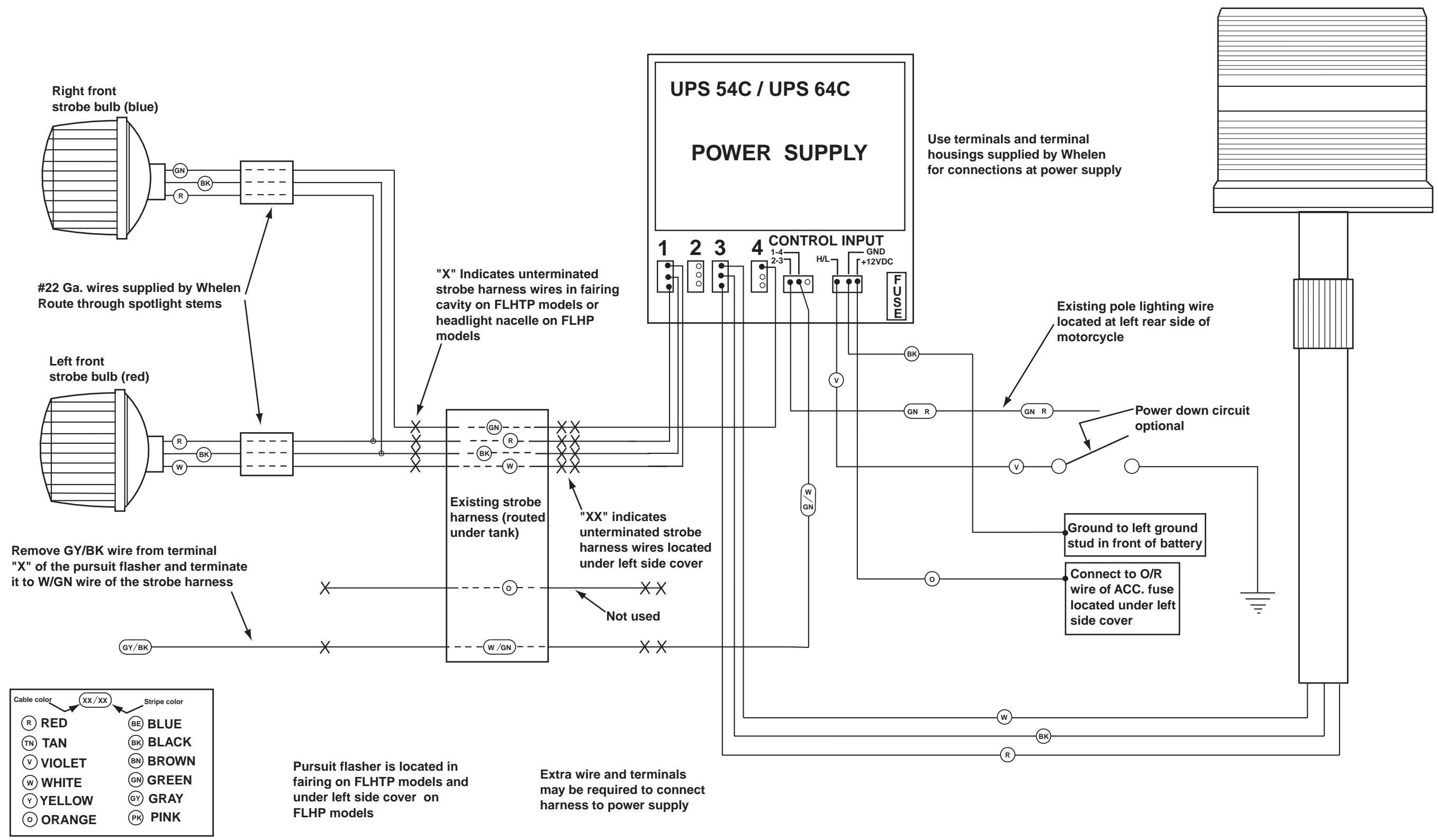

Figure A-17. 2008 FLHTP, FLHP and FLHPE, DOMESTIC and INTERNATIONAL Models, Optional Strobe System

Figure A-17.

**2008 FLHTP, FLHP and FLHPE, DOMESTIC and INTERNATIONAL
Models, Optional Strobe System**

Figure A-17.

**2008 FLHTP, FLHP and FLHPE, DOMESTIC and INTERNATIONAL
Models, Optional Strobe System**

SUBJECT

PAGE NO.

B.1 GLOSSARY.....B-1

NOTES

ACRONYMS AND ABBREVIATIONS

Table B-1. Acronyms and Abbreviations

ACRONYM OR ABBREVIATION	DESCRIPTION
A	Amperes
AC	Alternating Current
ACC	Accessory
ACR	Automatic Compression Release
AGM	Absorbed Glass Mat (battery)
AMP	Ampere
AWG	American Wire Gauge
B+	Battery Voltage
BAS	Bank Angle Sensor
BTDC	Before Top Dead Center
C	Celsius (Centigrade)
CA	California
CAL	Calibration
CC	Cubic Centimeters
CCA	Cold Cranking Amps
CKP	Crankshaft Position
cm	Centimeter
DC	Direct Current
DLC	Data Link Connector
DOM	Domestic
DTC	Diagnostic Trouble Code
DVOM	Digital Volt Ohm Meter
ECM	Electronic Control Module
ECT	Engine Coolant Temperature
EEPROM	Electrically Erasable Programmable Read Only Memory
EFI	Electronic Fuel Injection
ET	Engine Temperature
EVAP	Evaporative Emissions Control System
F	Fahrenheit
ft-lbs	Foot-Pounds
fl oz.	Fluid Ounce
g	Gram
GAL	Gallon
GAWR	Gross Axle Weight Rating
GND	Ground (electrical)
GVWR	Gross Vehicle Weight Rating
HDI	Harley-Davidson International
H-DSSS	Harley-Davidson Smart Security System
HFSM	Hands Free Security Module
Hg	Mercury
IAC	Idle Air Control

Table B-1. Acronyms and Abbreviations

ACRONYM OR ABBREVIATION	DESCRIPTION
IAT	Intake Air Temperature
ID	Inside Diameter
IGN	Ignition Light/Key Switch
IM	Instrument Module
In.	Inch
INJ PW	Injector Pulse Width
in-lbs	Inch-Pounds
Kg	Kilogram
Km	Kilometer
kPa	Kilopascal
km/hr	Kilometers Per Hour
L	Liter
LCD	Liquid Crystal Display
LED	Light Emitting Diode
mA	Milliampere
MAP	Manifold Absolute Pressure
ml	milliliter
mm	millimeter
MPH	Miles Per Hour
ms	millisecond
Nm	Newton-Meter
N/A	Not Applicable
no.	Number
O ₂	Oxygen
OD	Outside Diameter
OEM	Original Equipment Manufacturer
oz	Ounce
P&A	Parts and Accessories
PN	Part Number
PSI	Pounds per Square Inch
RES	Reserve
RPM	Revolutions Per Minute
SCFH	Cubic Feet per Hour at Standard Conditions
TCA	Throttle Control Actuator
TDC	Top Dead Center
TGS	Twist Grip Sensor
TP	Throttle Position
TMAP	Intake Air Temperature/Manifold Absolute Pressure
TSM	Turn Signal Module
TSSM	Turn Signal/Security Module
V	Volt
VAC	Volts of Alternating Current
VDC	Volts of Direct Current

Table B-1. Acronyms and Abbreviations

ACRONYM OR ABBREVIATION	DESCRIPTION
VIN	Vehicle Identification Number
VSS	Vehicle Speed Sensor

NOTES

Tools Used in This Manual

PART NUMBER	TOOL NAME	NOTES
HD-33223-1	CYLINDER COMPRESSION GAUGE	8.5 AUTOMATIC COMPRESSION RELEASE, Compression Test
HD-34633	AIR SUSPENSION PUMP AND GAUGE	2.5 AIR SEAT RESERVOIR, Installation
HD-39787A	RIVET TOOL	2.6 SADDLEBAGS, Hinges
HD-41404-B	TEST CONNECTOR KIT	8.5 AUTOMATIC COMPRESSION RELEASE, Diagnostics
HD-48498	ACR SOLENOID SOCKET	8.5 AUTOMATIC COMPRESSION RELEASE, Removal
HD-48637	BREAK-OUT BOX	8.5 AUTOMATIC COMPRESSION RELEASE, Diagnostics
HD-97087-65B	HOSE CLAMP PLIERS	3.3 OIL COOLER, Installation

NOTES

2008 FLT Police Models Service Manual Supplement

FASTENER	TORQUE VALUE		NOTES
Air cleaner cover bracket screw	40-60 in-lbs	4.5-6.8 Nm	1.1 SCHEDULED MAINTENANCE, General
Air cleaner cover screw	36-60 in-lbs	4.1-6.8 Nm	1.1 SCHEDULED MAINTENANCE, General
Air reservoir bracket rear/top Phillips screws	20-30 in-lbs	2.3-3.4 Nm	2.5 AIR SEAT RESERVOIR, Installation
Air reservoir bracket rear/top Phillips screws	20-30 in-lbs	2.3-3.4 Nm	2.5 AIR SEAT RESERVOIR, Installation
Air spring set screw flange nuts	50-70 in-lbs	5.7-7.9 Nm	2.4 SEAT, Air Spring Replacement
Air spring top plate fasteners	36-60 in-lbs	4.1-6.8 Nm	2.4 SEAT, Air Spring Replacement
Automatic compression release (ACR)	11-15 ft-lbs	14.9-20.3 Nm	8.5 AUTOMATIC COMPRESSION RELEASE, Installation / Apply three equally spaced dots of LOCTITE 246 THREADLOCKER MEDIUM STRENGTH/HIGH TEMPERATURE around lower third of threads
Battery cable terminal bolt (10 mm)	60-96 in-lbs	6.8-10.9 Nm	2.4 SEAT, Air Spring Replacement
Battery hold-down clamp T40 TORX screw	15-20 ft-lbs	20-27 Nm	2.4 SEAT, Air Spring Replacement
Battery terminal bolt	60-96 in-lbs	6.8-10.9 Nm	1.1 SCHEDULED MAINTENANCE, General
Brake caliper pad pin	75-102 in-lbs	8.5-11.5 Nm	1.1 SCHEDULED MAINTENANCE, General
Chrome frame tube cover Phillips screw	25-40 in-lbs	2.8-4.5 Nm	2.5 AIR SEAT RESERVOIR, Installation
Clutch adjuster screw locknut	72-120 in-lbs	8.1-13.6 Nm	1.1 SCHEDULED MAINTENANCE, General
Clutch inspection cover	84-108 in-lbs	9.5-12.2 Nm	1.1 SCHEDULED MAINTENANCE, General
Engine oil drain plug	14-21 ft-lbs	19.0-28.5 Nm	1.1 SCHEDULED MAINTENANCE, General
Handlebar switch housing screw	35-45 in-lbs	4.0-5.1 Nm	1.1 SCHEDULED MAINTENANCE, General
Headlamp door Phillips screw	9-18 in-lbs	1.0-2.0 Nm	2.7 TACHOMETER BRACKET: FLHP/E, Installation
Headlamp housing Phillips screws (FLHP/E)	9-18 in-lbs	1.0-2.0 Nm	2.7 TACHOMETER BRACKET: FLHP/E, Installation
Headlamp nacelle chrome strip flange nut (FLHP/E)	15-20 in-lbs	1.7-2.3 Nm	2.7 TACHOMETER BRACKET: FLHP/E, Installation
Headlamp nacelle handlebar clamp shroud Phillips screw (FLHP/E)	10-20 in-lbs	1.1-2.3 Nm	2.7 TACHOMETER BRACKET: FLHP/E, Installation
License plate bracket to bottom support tube hex bolts	15-20 ft-lbs	20.3-27.1 Nm	2.5 AIR SEAT RESERVOIR, Installation
Luggage rack to frame tube weldment T40 TORX screws	15-20 ft-lbs	20.3-27.1 Nm	2.5 AIR SEAT RESERVOIR, Installation
Master cylinder reservoir cover screws, front	7-10 in-lbs	0.8-1.1 Nm	1.1 SCHEDULED MAINTENANCE, General
Master cylinder reservoir cover screws, rear	12-15 in-lbs	1.4-1.7 Nm	1.1 SCHEDULED MAINTENANCE, General
Oil cooler adapter inspection cover socket screws	90-120 in-lbs	10.2-13.6 Nm	3.3 OIL COOLER, Cleaning and Inspection / Use Loctite Medium Strength Threadlocker 243 (blue).
Oil Cooler mounting bracket flange nuts	70-100 in-lbs	7.9-11.3 Nm	3.3 OIL COOLER, Installation
Oil filter adapter	18-22 ft-lbs	24.4-29.8 Nm	3.3 OIL COOLER, Oil Cooler Adapter and Thermostat Replacement / Apply Loctite High Temperature/Medium Strength Threadlocker 246.
Primary chaincase drain plug	14-21 ft-lbs	19.0-28.5 Nm	1.1 SCHEDULED MAINTENANCE, General
Saddlebag lockset hex nut	25-35 in-lbs	2.8-4.0 Nm	2.6 SADDLEBAGS, Lockset
Saddlebag lockset jam nut	30-45 in-lbs	3.4-5.1 Nm	2.6 SADDLEBAGS, Lockset
Saddlebag mounting bracket hex bolt	60-96 in-lbs	6.8-10.8 Nm	2.5 AIR SEAT RESERVOIR, Installation
Saddlebag tether T15 TORX screw	20-25 in-lbs	2.3-2.8 Nm	2.6 SADDLEBAGS, Tether / Use Loctite High Strength Threadlocker 262 (red).

2008 FLT Police Models Service Manual Supplement

FASTENER	TORQUE VALUE		NOTES
Seat bracket mount fasteners	15-20 ft-lbs	20.3-27.1 Nm	2.4 SEAT, Seat Bracket Mount Replacement
Seat fairing fastener	60-120 in-lbs	6.8-13.6 Nm	2.4 SEAT, Seat Installation
Seat fairing fastener	60-120 in-lbs	6.8-13.6 Nm	2.4 SEAT, Air Spring Replacement
Seat hex screw, front	60-120 in-lbs	6.8-13.6 Nm	2.4 SEAT, Seat Installation
Seat pivot bolt and acorn nut	48-84 in-lbs	5.4-9.5 Nm	2.4 SEAT, Seat Installation
Seat stud flange nuts, rear	96-144 in-lbs	10.9-16.3 Nm	2.4 SEAT, Seat Installation
Spark plugs	12-18 ft-lbs	16.3-24.4 Nm	1.1 SCHEDULED MAINTENANCE, General
Spoke nipples	55 in-lbs	6.2 Nm	1.1 SCHEDULED MAINTENANCE, General
Tachometer bracket acorn nuts (FLHP/E)	72-108 in-lbs	8.1-12.2 Nm	2.7 TACHOMETER BRACKET: FLHP/E, Installation
Top caddy clamp screw	15-20 ft-lbs	20-27 Nm	1.1 SCHEDULED MAINTENANCE, General
Transmission drain plug	14-21 ft-lbs	19.0-28.5 Nm	1.1 SCHEDULED MAINTENANCE, General
Transmission filler plug/dipstick	25-75 in-lbs	2.8-8.5 Nm	1.1 SCHEDULED MAINTENANCE, General

A	
Automatic Compression Release (ACR)	
Compression Test	8-11
Diagnostics	8-12
General	8-10
Installation	8-10
Removal	8-10
B	
Bulb Chart	8-1
C	
Connector Locations	A-1
F	
Foreword	
Important General Information	i-I
G	
Glossary	
Acronyms and Abbreviations	B-1
H	
Handlebar Switches	
Clutch Interlock Switch	8-7
Horn and Siren Yelp Switch	8-6
Pursuit and Auxiliary Switch	8-8
L	
Loctite	i-II
M	
Maintenance	
Periodic	1-1
O	
Oil Cooler	
Cleaning and Inspection	3-4
Installation	3-4
Oil Cooler Adapter and Thermostat Replacement	3-4
Operation	3-3
Removal	3-3
R	
Rear Marker Lights	
Installation	8-5
Marker Lights Replacement	8-5
Removal	8-5
S	
Saddlebag	
Hinge Replacement	2-11
Knob and Spring Latch	2-12
Lockset	2-11
Lockset Catch	2-11
Spring Latch Bracket	2-13
Tether	2-12
Tether Brackets	2-12
Scheduled Maintenance	1-1
Seat	
Air Reservoir Installation	2-9
Air Reservoir Removal	2-8
Air Spring Replacement	2-6
General Information	2-4
Seat Bracket Replacement	2-7
Seat Installation	2-6
Seat Removal	2-6

Service Aids	
Lubricants, Greases, Sealants	1-3
Service Bulletins	i-I
Service Preparation	i-I
Service Wear Limits	
General	3-2
Specifications	
Chassis	2-1
Engine	3-1
Quick Reference	1-1
SPX Kent-Moore	i-II
System Fuses and Relays	8-3
T	
Tachometer Bracket: FLHP/E	
Installation	2-15
Removal	2-14
Tires	2-3
Trademarks	
Harley-Davidson	i-II
Referenced Products	i-II
V	
Vehicle Identification Number (VIN)	2-2
W	
Wiring Diagrams	A-7

NOTES

INSIDE BACK COVER GOES HERE

OUTSIDE BACK COVER GOES HERE