

LEISTER

PLASTIC WELDING

Hot-Air Hand Tools

2019/2020

Swiss
made

General accessories









www.leister.com/accessories

Product overview

Hot-air hand tools









Type	TRIAC ST	TRIAC AT	ELECTRON ST	HOT JET S	SOLANO AT	GHIBLI AW	GHIBLI	HOTWIND	FORTE S3
Voltage V~	230 / 120	230 / 120	230 / 120	230 / 120	230	120/230	120/230	230	3 × 230 / 3 × 400
Max. power W	1600	1600	2400 / 3400	460	2300	1800 / 2300	1500 / 2000	3700	10 000
Temperature °C	40 – 700	40 – 620	40 – 650	40 – 600	50 - 650	65 – 620	40 – 600	20 – 650	20 – 650
Size mm (L × W × H) Handle (∅)	338 × 90 56	338 × 90 56	338 × 90 56	235 × 70 40	270 × 75 × 240 45	280 × 90 × 220 45	195 × 85 × 160 57	332 × 106 × 179	390 × 132 85
Weight kg (without cord)~	1.0	1.0	1.1	0.4	0.75	1.1	0.9	2.2	4.4
Integrated blower	✓	✓	✓	✓	✓	✓	✓	✓	✓
Digital display		✓			✓	✓		✓(SYSTEM)	
Conformity mark	CE	CE	CE	CE	CE	CE	CE		CE
Approval mark	Ⓢ Ⓚ	Ⓢ Ⓚ	Ⓢ Ⓚ	Ⓢ Ⓚ	Ⓚ	Ⓢ		Ⓚ	Ⓢ
Protection class	□	□	□	□	□	□	□	□	□
Applications									
Outdoor use	✓	✓	✓	✓		✓			✓
Roofing 	✓	✓	✓	✓					
Billboards / Tarpaulins 	✓	✓		✓	✓				
Civil engineering / Tunneling / Landfills 	✓	✓	✓						
Plastic fabrication 	✓	✓		✓					
Flooring / Interior design 	✓	✓	✓	✓					
Shrinking 	✓	✓	✓	✓	✓	✓	✓	✓	✓
Special applications 					✓	✓	✓	✓	✓



Hot-air hand tools and Blower



Type	AIRSTREAM ST	ROBUST	WELDING PEN R / S	DIODE PID / S	MINOR	LABOR S
Voltage V~	230	3 × 230 / 3 × 400	230	230	230	230
Max. power W	215	250	1000	1600 / 2000	100	800 / 900
Temperature °C			20 – 600	20 – 600		20 – 600
Size mm (L × W × H) Handle (Ø)	600 × 250 × 362	255 × 221	270 × 43 32	265 × 57 40	250 × 95 64	180 × 54 32
Weight kg (without cord)~	24	8.0	1.0	1.15	1.15	0.15
Integrated blower	✓	✓			✓	
Digital display			✓ (R)	✓ (PID)		
Conformity Mark	CE		CE	CE	CE	CE
Approval mark						
Protection Class	⊕	⊕	⊠	⊠	⊠	⊠
Applications						
Indoor use	✓	✓	✓	✓	✓	✓
Roofing 						
Billboards / Tarpaulins 						
Civil engineering / Tunneling / Landfills 						
Plastic fabrication 	✓	✓	✓	✓	✓	✓
Flooring / Interior design 						
Shrinking 	✓			✓		✓



Accessories Hot-Air Hand Tools

Wide slot nozzles



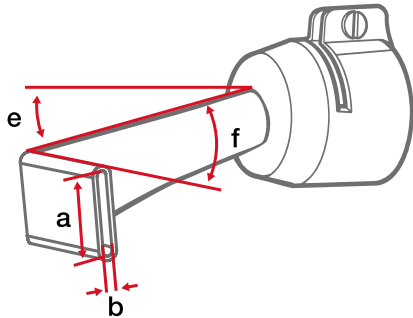











Wide slot nozzle: a x b mm, e° angled, f° bent







Wide slot nozzle Ø21.3 mm



	TRIAC ST / AT	ELECTRON ST	HOT JET S	GHIBLI / GHIBLI AW	SOLANO AT	WELDING PEN R / S	DIODE PID / S	LABOR S
 105.549 10 x 2 mm, 15° angled, 30° bent			•					•
 107.141 15 x 2 mm, 15° angled, 30° bent			•					•
 105.559 20 x 2 mm, straight			•					•
 107.142 ¹⁾ 20 x 2 mm, 30° angled			•					•
 105.556 20 x 2 mm, 75° angled			•					•
 105.070 25 x 1 mm, straight			•					•
 105.066 30 x 1 mm, straight			•					•
 105.548 40 x 5 mm, straight			•					•
 105.547 50 x 8 mm, straight			•					•
 105.039 80 x 1 mm, straight			•					•
 105.036 100 x 1 mm, straight			•					•

Wide slot nozzle Ø31.5 mm

	TRIAC ST / AT	ELECTRON ST	HOT JET S	GHIBLI / GHIBLI AW	SOLANO AT	WELDING PEN R / S	DIODE PID / S	LABOR S
 105.475 20 x 2 mm, straight	•							•
NEW  105.477 20 x 2 mm, straight, 150 mm length	•							•
 107.123 ¹⁾ 20 x 2 mm, 15° angled	•							•
 107.125 ¹⁾ 20 x 2 mm, 60° angled, foil left	•							•
 105.503 ¹⁾ 20 x 2 mm, 60° angled, foil right	•							•
 107.124 ¹⁾ 20 x 2 mm, 75° angled	•							•
 124.999 20 x 3 mm, 15° angled, 120° bent, foil left	•							•
 105.500 20 x 3 mm, 15° angled, -120° bent, foil right	•							•
 105.492 20 x 2 mm, 15° angled, 120° bent	•							•
 105.487 ¹⁾ 20 x 2 mm, -15° angled, 30° bent	•							•
 160.858 20 x 9 mm, straight	•							•
 105.485 25 x 2 mm, straight	•							•
 105.494 30 x 2 mm, 15° angled	•							•
 128.535 30 x 2 mm, 45° angled	•							•
 105.526 40 x 2 mm, straight	•							•

Wide slot nozzle $\varnothing 31.5$ mm		TRIAC ST / AT	ELECTRON ST	HOT JET S	GHIBLI / GHIBLI AW	SOLANO AT	WELDING PENR / S	DIODE PID / S	LABOR S
	107.132 ¹⁾ 40 x 2 mm, 15° angled	•							•
	107.133 40 x 2 mm, 15° angled, perforated	•							•
	107.143 40 x 2 mm, 15° angled, with stop plate	•							•
	107.135 40 x 2 mm, 15° angled, PTFE-coated	•							•
	107.130 40 x 2 mm, 60° angled	•							•
	105.531 40 x 2 mm, 90° angled,	•							•
	105.527 40 x 8 mm, 30° bent	•							•
	107.129 ¹⁾ 60 x 2 mm, 15° angled, for Bitumen	•							•
	107.131 ¹⁾ 80 x 2 mm, 15° angled, for Bitumen	•							•

Wide slot nozzle $\varnothing 36.5$ mm		TRIAC ST / AT	ELECTRON ST	HOT JET S	GHIBLI / GHIBLI AW	SOLANO AT	WELDING PENR / S	DIODE PID / S	LABOR S
	105.435 20 x 2 mm, straight, without clamps				•	•			
	106.998 ¹⁾ 20 x 2 mm, 15° angled				•	•			
	106.999 ¹⁾ 40 x 2 mm, -15° angled				•	•			
	108.086 40 x 2 mm, straight, without clamps				•	•			
	107.261 70 x 4 mm, straight, without clamps				•	•			

Wide slot nozzle $\varnothing 36.5$ mm		TRIAC ST / AT	ELECTRON ST	HOT JET S	GHIBLI / GHIBLI AW	SOLANO AT	WELDING PENR / S	DIODE PID / S	LABOR S
	108.078 100 x 4 mm, straight				•	•			
	105.982 150 x 4 mm, straight				•	•			

Wide slot nozzle $\varnothing 50.0$ mm		TRIAC ST / AT	ELECTRON ST	HOT JET S	GHIBLI / GHIBLI AW	SOLANO AT	WELDING PENR / S	DIODE PID / S	LABOR S
	107.134 40 x 2 mm, straight, for tape welding				•				
	105.961 42 x 11 mm, length 300 mm				•				
	107.258 ¹⁾ 70 x 10 mm, straight, for Bitumen, without clamps				•				
	142.281 ²⁾ 74 x 3 mm, with scraper				•				
	107.653 ²⁾ 75 x 2 mm, 20° angled, for Bitumen				•				
	106.057 100 x 4 mm, straight, without clamps				•				
	106.060 150 x 6 mm, straight, without clamps				•				
	107.270 150 x 12 mm, straight, without clamps				•				
	106.061 300 x 6 mm, straight				•				







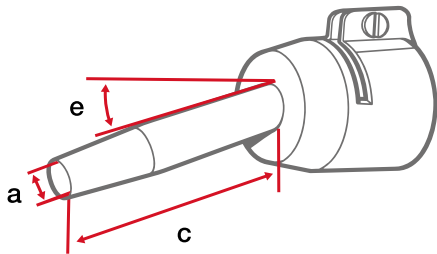

¹⁾ POS cardboard box available (please refer to p. 18 / 19)
²⁾ Tool stand 151.068 recommended (please refer to p. 14)

Tubular nozzles



Tubular nozzle: $\varnothing a$ mm, c mm, e° angled



Tubular nozzle $\varnothing 21.3$ mm

		TRIAC ST / AT	ELECTRON ST	HOT JET S	GHIBLI / GHIBLI AW	SOLANO AT	WELDING PEN R / S	DIODE PID / S	LABOR S
	105.624 $\varnothing 4$ mm, 45 mm, straight			•					•
	107.144 ¹⁾ $\varnothing 5$ mm, 41 mm, 15° angled, suitable for speed welding nozzle			•					•
	105.566 $\varnothing 5$ mm, 45 mm, straight, suitable for speed welding nozzle			•					•
	105.567 $\varnothing 5$ mm, 150 mm, straight, suitable for speed welding nozzle			•					•
	131.867 $\varnothing 5$ mm, 30 x 60 mm, 90° bent, suitable for speed welding nozzle			•					•
	105.618 $\varnothing 7$ mm, 30 mm, straight			•					•
	107.145 $\varnothing 10$ mm, 45 mm, straight			•					•
	107.152 $\varnothing 12$ mm, 25 x 50 mm, 90° angled			•					•
	105.641 $\varnothing 21.3$ mm, 33 x 45 mm, 90° angled			•					•

Soldering nozzle $\varnothing 21.3$ mm

	105.614 3 x 1.5 mm, 30 mm, straight			•					•
	107.148 3 x 1.5 mm, 40 mm, 45° angled			•					•

Tubular nozzle: $\varnothing a$ mm, c x d mm, e° angled

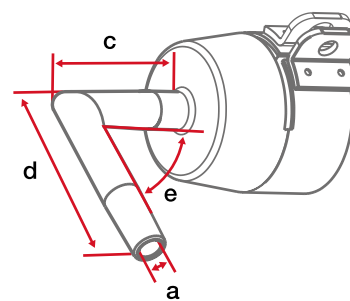













Soldering nozzle $\varnothing 21.3$ mm



		TRIAC ST / AT	ELECTRON ST	HOT JET S	GHIBLI / GHIBLI AW	SOLANO AT	WELDING PEN R / S	DIODE PID / S	LABOR S
	107.147 $\varnothing 1.5$ mm, 30 mm, 45° angled			•					•
	107.146 $\varnothing 2$ mm, 40 mm, 45° angled			•					•
	107.150 $\varnothing 2.5$ mm, 45 mm, 45° angled			•					•
	107.151 $\varnothing 4$ mm, 45 mm, 45° angled			•					•
	107.149 $\varnothing 7$ mm, 40 mm, 20° angled			•					•



Tubular nozzle $\varnothing 31.5$ mm

	107.000 $\varnothing 5$ mm, 27 - 39 mm, straight (triplicate)			•					•
	100.303 ¹⁾ $\varnothing 5$ mm, 37 mm, 15° angled, suitable for speed welding nozzle			•					•
	105.576 $\varnothing 5$ mm, 30 x 60 mm, 90° bent, suitable for speed welding nozzle			•					•
	105.575 $\varnothing 5$ mm, 100 mm, straight, suitable for speed welding nozzle			•					•
	106.982 $\varnothing 5$ mm, 150 mm, -15° angled, suitable for speed welding nozzle			•					•
	105.429 $\varnothing 5$ mm, 200 mm, straight, suitable for speed welding nozzle			•					•

Tubular nozzle $\varnothing 31.5$ mm		TRIAC ST / AT	ELECTRON ST	HOT JET S	GHIBLI / GHIBLI AW	SOLANO AT	WELDING PENR / S	DIODE PID / S	LABOR S
	107.128 $\varnothing 10$ mm, 44 mm, straight	•						•	
	105.514 $\varnothing 14$ mm, 25 x 50 mm, 90° angled	•						•	
	111.711 $\varnothing 18$ mm, 70 mm, straight	•						•	

Tubular nozzle $\varnothing 36.5$ mm		TRIAC ST / AT	ELECTRON ST	HOT JET S	GHIBLI / GHIBLI AW	SOLANO AT	WELDING PENR / S	DIODE PID / S	LABOR S
	107.154 ¹⁾ $\varnothing 5$ mm, 41 mm, straight, suitable for speed welding nozzle				•	•			
	107.006 $\varnothing 5$ mm, 130 mm, straight				•	•			
	105.818 $\varnothing 5$ mm, 150 mm, straight, suitable for speed welding nozzle				•	•			
	105.454 $\varnothing 9$ mm, 50 mm, straight, without clamps				•	•			
	105.455 $\varnothing 9$ mm, 102 mm, straight, without clamps				•	•			
	107.002 $\varnothing 12$ mm, 25 x 50 mm, 90° angled				•	•			
	107.003 $\varnothing 12$ mm, 25 x 50 mm, 90° angled, without clamps				•	•			
	105.462 $\varnothing 21.3$ mm, 58 mm, straight, without clamps				•	•			
	105.446 $\varnothing 25$ mm, 25 x 95 mm, 90° angled				•	•			

Tubular nozzle $\varnothing 50.0$ mm		TRIAC ST / AT	ELECTRON ST	HOT JET S	GHIBLI / GHIBLI AW	SOLANO AT	WELDING PENR / S	DIODE PID / S	LABOR S
	107.229 $\varnothing 20$ mm, without clamps	•							
	107.256 $\varnothing 48$ mm, 85 x 165 mm, 90° angled	•							

Tubular nozzle M14		TRIAC ST / AT	ELECTRON ST	HOT JET S	GHIBLI / GHIBLI AW	SOLANO AT	WELDING PENR / S	DIODE PID / S	LABOR S
	116.519 $\varnothing 5$ mm, 43 mm, straight, suitable for speed welding nozzle								•
	105.622 $\varnothing 5$ mm, 43 mm, 15° angled, suitable for speed welding nozzle								•







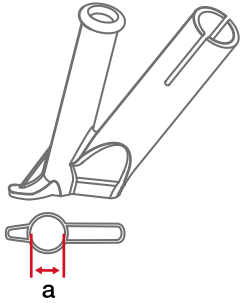













¹⁾ POS cardboard box available (please refer to p. 18 / 19)

Speed welding nozzles



Speed welding nozzle: a mm



Speed welding nozzle $\varnothing 8.0$ mm

	TRIAC ST / AT	ELECTRON ST	HOT JET S	GHIBLI / GHIBLI AW	SOLANO AT	WELDING PEN R / S	DIODE PID / S	LABOR S
 106.989 ³⁾ Round $\varnothing 3$ mm Profile D 	•	•	•	•	•	•	•	•
 105.431 ¹⁾³⁾ Round $\varnothing 3$ mm, with narrow air slit Profile D 	•	•	•	•	•	•	•	•
NEW  160.550 ¹⁾³⁾ Round $\varnothing 3$ mm, with narrow air slit, tip bent Profile D 	•	•	•	•	•	•	•	•
 106.990 ³⁾ Round $\varnothing 4$ mm Profile D 	•	•	•	•	•	•	•	•
 105.432 ¹⁾³⁾ Round $\varnothing 4$ mm, with narrow air slit Profile D 	•	•	•	•	•	•	•	•
 106.991 ¹⁾³⁾ Round $\varnothing 5$ mm Profile D 	•	•	•	•	•	•	•	•
 105.433 ¹⁾³⁾ Round $\varnothing 5$ mm, with narrow air slit Profile D 	•	•	•	•	•	•	•	•
NEW  159.848 ¹⁾³⁾ Round $\varnothing 5$ mm, with narrow air slit, tip bent Profile D 	•	•	•	•	•	•	•	•
 156.470 ³⁾ Round $\varnothing 5$ mm, tip bent Profile D 	•	•	•	•	•	•	•	•
 107.137 ³⁾ Tape 8 x 2 mm Profile C 	•	•	•	•	•	•	•	•
 107.139 ³⁾ Tape 12 x 4.5 mm Profile C 	•	•	•	•	•	•	•	•
 106.992 ³⁾ Triangle 5.7 x 3.7 mm Profile A 	•	•	•	•	•	•	•	•

Speed welding nozzle $\varnothing 8.0$ mm

	TRIAC ST / AT	ELECTRON ST	HOT JET S	GHIBLI / GHIBLI AW	SOLANO AT	WELDING PEN R / S	DIODE PID / S	LABOR S
 106.993 ³⁾ Triangle 7 x 5 mm Profile B 	•	•	•	•	•	•	•	•

Smoothing nozzle $\varnothing 8.0$ mm

	TRIAC ST / AT	ELECTRON ST	HOT JET S	GHIBLI / GHIBLI AW	SOLANO AT	WELDING PEN R / S	DIODE PID / S	LABOR S
NEW  165.937 ³⁾ for welded seams in corners and curves	•	•	•	•	•	•	•	•













Tacking nozzle $\varnothing 8.0$ mm

	TRIAC ST / AT	ELECTRON ST	HOT JET S	GHIBLI / GHIBLI AW	SOLANO AT	WELDING PEN R / S	DIODE PID / S	LABOR S
 106.996 ³⁾ $\varnothing 8$ mm	•	•	•	•	•	•	•	•

Tacking nozzle M14

	TRIAC ST / AT	ELECTRON ST	HOT JET S	GHIBLI / GHIBLI AW	SOLANO AT	WELDING PEN R / S	DIODE PID / S	LABOR S
 106.988 M14						•		

Drawing nozzle (M14)

 113.876 Round $\varnothing 3$ mm, without tacking tip Profile D 						•		
 113.666 Round $\varnothing 3$ mm, with tacking tip Profile D 						•		
 113.874 Round $\varnothing 4$ mm, without tacking tip Profile D 						•		
 113.399 Round $\varnothing 4$ mm, with tacking tip Profile D 						•		
 126.552 Round $\varnothing 4$ mm, for Fluoroplastics Profile D 						•		
 113.877 Triangle, 5.7 x 3.7 mm, without tacking tip Profile A 						•		

¹⁾ POS cardboard box available (please refer to p. 18 / 19)







³⁾ suitable tubular nozzle required





Flooring / Interior Decoration
 Technical Textiles / Industrial Fabrics

Roofing
 Shrinking



Civil Engineering / GEO
 Plastic Fabrication

Special applications

Drawing nozzle (M14)		TRIAC ST / AT	ELECTRON ST	HOT JET S	GHIBLI / GHIBLI AW	SOLANO AT	WELDING PEN R / S	DIODE PID / S	LABOR S
	113.670 Triangle, 5.7 x 3.7 mm, with tacking tip Profile A 						•		
	106.986 Triangle, 7 x 5 mm, without tacking tip Profile B 						•		
	106.987 Triangle, 7 x 5.5 mm, without tacking tip 						•		

Speed welding nozzle $\varnothing 31.5$ mm		TRIAC ST / AT	ELECTRON ST	HOT JET S	GHIBLI / GHIBLI AW	SOLANO AT	WELDING PEN R / S	DIODE PID / S	LABOR S
	113.183 Tape 21 x 4 mm 	•						•	
	107.136 Tape 25 x 4 mm 	•						•	

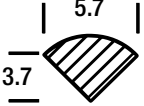
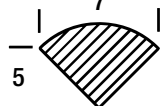

Profile size in mm

Profile A	Profile B	Profile C	Profile D
			

Welding rods please refer to p. 16



Sieve reflector $\varnothing 21.3$ mm		TRIAC ST / AT	ELECTRON ST	HOT JET S	GHIBLI / GHIBLI AW	SOLANO AT	WELDING PENR / S	DIODE PID / S	LABOR S
---------------------------------------	--	---------------	-------------	-----------	--------------------	-----------	------------------	---------------	---------

	107.310 35 x 20 mm, 75° angled			•					•
	107.311 50 x 34 mm, 75° angled			•					•



Sieve reflector $\varnothing 31.5$ mm		TRIAC ST / AT	ELECTRON ST	HOT JET S	GHIBLI / GHIBLI AW	SOLANO AT	WELDING PENR / S	DIODE PID / S	LABOR S
---------------------------------------	--	---------------	-------------	-----------	--------------------	-----------	------------------	---------------	---------

	107.338 35 x 20 mm, 90° angled, without clamps	•							•
	107.337 50 x 34 mm, 75° angled, without clamps	•							•
NEW 	106.161 50 x 34 mm, straight	•							•
	118.845 60 x 57 x 45 mm, straight, without clamps	•							•

Sieve reflector $\varnothing 36.5$ mm		TRIAC ST / AT	ELECTRON ST	HOT JET S	GHIBLI / GHIBLI AW	SOLANO AT	WELDING PENR / S	DIODE PID / S	LABOR S
---------------------------------------	--	---------------	-------------	-----------	--------------------	-----------	------------------	---------------	---------

	107.309 35 x 20 mm, 75° angled, without clamps				•	•			
	107.308 50 x 34 mm, 75° angled, without clamps				•	•			
	112.068 50 x 34 mm, straight, without clamps				•	•			
	127.137 60 x 57 x 45 mm, straight, without clamps				•	•			
	107.318 $\varnothing 65$ mm, straight				•	•			
	107.319 $\varnothing 65$ mm, straight, without clamps				•	•			





Sieve reflector $\varnothing 50.0$ mm		TRIAC ST / AT	ELECTRON ST	HOT JET S	GHIBLI / GHIBLI AW	SOLANO AT	WELDING PENR / S	DIODE PID / S	LABOR S
---------------------------------------	--	---------------	-------------	-----------	--------------------	-----------	------------------	---------------	---------

	107.327 75 x 70 x 90 mm, straight, without clamps			•					
	107.333 150 x 110 x 137 mm, straight, without clamps			•					
	106.127 $\varnothing 65$ mm, straight, without clamps			•					



Special nozzles

Ironig nozzle $\varnothing 21.3$ mm

	TRIAC ST / AT	ELECTRON ST	HOT JET S	GHIBLI / GHIBLI AW	SOLANO AT	WELDING PEN R / S	DIODE PID / S	LABOR S
 107.305 15 x 25 mm Profile dimension 			•					•
 114.734 40 x 20 mm Profile dimension for ski repairs 			•					•

De-horning nozzle $\varnothing 36.5$ mm

 107.007 $\varnothing 20$ mm, 58 mm, straight 				•	•			
-------------------------------------------------------------------------------------------------------------------------------------------------------------------------------------------------------------------------------	--	--	--	---	---	--	--	--

Protection nozzle $\varnothing 31.5$ mm

 157.717 $\varnothing 23$ mm, protection ring $\varnothing 80$ mm 								•
--------------------------------------------------------------------------------------------------------------------------------------------------------------------------------------------------------------------------------------------------------	--	--	--	--	--	--	--	---

Protection nozzle $\varnothing 36.5$ mm

 158.474 $\varnothing 23$ mm, protection ring $\varnothing 80$ mm 				•	•			
----------------------------------------------------------------------------------------------------------------------------------------------------------------------------------------------------------------------------------------------------------	--	--	--	---	---	--	--	--

Protection nozzle $\varnothing 50.0$ mm

 160.842 $\varnothing 44$ mm, Protection ring $\varnothing 100$ mm 								•
-----------------------------------------------------------------------------------------------------------------------------------------------------------------------------------------------------------------------------------------------------------	--	--	--	--	--	--	--	---



Adapter $\varnothing 21.3$ mm

 143.831 to M14 				•				
-----------------------------------------------------------------------------------------------------------------------------------------------------------------------------------------------------	--	--	--	---	--	--	--	--







Adapter $\varnothing 31.5$ mm

 143.833 to M14 				•				•
-----------------------------------------------------------------------------------------------------------------------------------------------------------------------------------------------------	--	--	--	---	--	--	--	---

Adapter $\varnothing 50.0$ mm

	TRIAC ST / AT	ELECTRON ST	HOT JET S	GHIBLI / GHIBLI AW	SOLANO AT	WELDING PEN R / S	DIODE PID / S	LABOR S
 122.924 to $\varnothing 36.5$ mm 			•					

Adapter (M14)

 141.375 to $\varnothing 21.3$ mm 								•
 127.726 to M14, 30° angled 								•
 127.727 to M14, 45° angled 								•





Welding mirror $\varnothing 31.5$ mm

 107.344 $\varnothing 135$ mm 								•
-------------------------------------------------------------------------------------------------------------------------------------------------------------------------------------------------------------------	--	--	--	--	--	--	--	---

Welding mirror $\varnothing 36.5$ mm

 107.345 $\varnothing 135$ mm 				•	•			
-------------------------------------------------------------------------------------------------------------------------------------------------------------------------------------------------------------------	--	--	--	---	---	--	--	--

Welding mirror $\varnothing 50.0$ mm

 107.346 $\varnothing 270$ mm 								•
 107.347 74 x 12 x 520 mm, edges rounded, PTFE-coated 								•

Pressure roller

a mm (material of the roller)

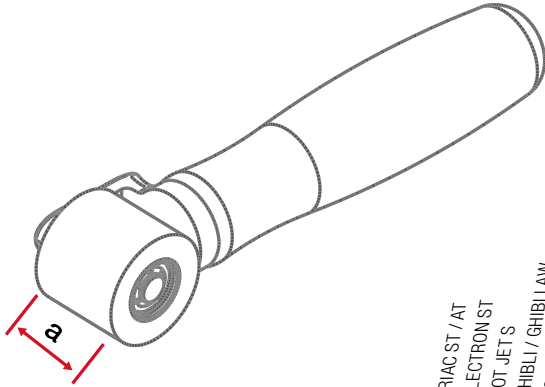

		TRIAC ST / AT	ELECTRON ST	HOT JET S	GIBLI / GIBLI AW	SOLANO AT	WELDING PEN R / S	DIODE PID / S	LABOR S
	106.976 ¹⁾ 28 mm (PTFE), with ball bearing	•	•	•	•	•	•	•	•
	140.161 ¹⁾ 28 mm (silicone), with ball bearing	•	•	•	•	•	•	•	•
	140.598 Spare roll for 140.161	•	•	•	•	•	•	•	•
	140.160 ¹⁾ 40 mm (silicone), with ball bearing	•	•	•	•	•	•	•	•
	140.599 Spare roll for 140.160	•	•	•	•	•	•	•	•
	106.974 80 mm (silicone)	•	•	•	•	•	•	•	•
	106.972 ¹⁾ 6 mm (brass), with ball bearing	•	•	•	•	•	•	•	•
	106.971 7 mm (brass), for welding rod Ø2 - 4 mm	•	•	•	•	•	•	•	•
	106.970 ¹⁾ 7 mm (brass), for welding rod Ø4 - 5 mm	•	•	•	•	•	•	•	•
	106.981 16 mm (steel & silicone)	•	•	•	•	•	•	•	•
	108.190 16 mm (silicone)	•	•	•	•	•	•	•	•

Roll

		TRIAC ST / AT	ELECTRON ST	HOT JET S	GIBLI / GIBLI AW	SOLANO AT	WELDING PEN R / S	DIODE PID / S	LABOR S
	111.788 Spare roll for 108.190 and 106.981	•	•	•	•	•	•	•	•

Planer and spare blades











	111.346 Chamfer planer for Z spare blades for sealing sheets	•	•	•	•	•	•	•	•
	151.188 Spare blade for 111.346	•	•	•	•	•	•	•	•
	106.966 Hand grooving tool	•	•	•	•	•	•	•	•
	106.968 Spare blade for 106.966	•	•	•	•	•	•	•	•
	151.188 ¹⁾ Chamfer planer for T-joints for sealing sheets	•	•	•	•	•	•	•	•
	150.809 Hand grooving tool «GROOVY», 3.5 mm for weldable floor coverings	•	•	•	•	•	•	•	•

Various accessories

	138.314 ¹⁾ Seam probe tester for overlap seams	•	•	•	•	•	•	•	•
	154.026 Scraper blade	•	•	•	•	•	•	•	•
	165.734 3 spare blades for 154.026	•	•	•	•	•	•	•	•
	154.259 Contour scraper	•	•	•	•	•	•	•	•

¹⁾ POS cardboard box available (please refer to p. 18 / 19)



Various accessories

		TRIAC ST / AT	ELECTRON ST	HOT JET S	GHIBLI / GHIBLI AW	SOLANO AT	WELDING PEN R / S	DIODE PID / S	LABOR S
	137.855 ¹⁾ Leister cutter with holster and 4 spare blades	•	•	•	•	•	•	•	•
	138.902 Hooked blades for 137.855 (10 dispenser with 10 pcs = 100 pcs)	•	•	•	•	•	•	•	•
	138.539 Straight-edge blades for 137.855 (10 dispenser with 10 pcs = 100 pcs)	•	•	•	•	•	•	•	•
	151.382 ¹⁾ Inside corner tool	•	•	•	•	•	•	•	•
	153.009 Plastfix	•	•	•	•	•	•	•	•
	152.676 Leister weld seam template	•	•	•	•	•	•	•	•
	159.514 Seam inspection template	•	•	•	•	•	•	•	•
	157.544 Leister Universal scissors 260 mm with special shaft grinding	•	•	•	•	•	•	•	•
	116.798 ¹⁾ Brass brush	•	•	•	•	•	•	•	•
	142.647 Brass brush Ø3 mm	•	•	•	•	•	•	•	•
	106.997 Ø 6 mm rotary burr for drilling machine, for car repairs	•	•	•	•	•	•	•	•

Cutting tools

	106.969 ¹⁾ Quarter Moon Knife including leather case, 100 mm stainless steel blade	•	•	•	•	•	•	•	•
	122.541 ¹⁾ Trimming guide to use with 106.969	•	•	•	•	•	•	•	•
	117.000 Trimming knife with 0.6 mm spacer for vinyl and linoleum with 5 spare blades included	•	•	•	•	•	•	•	•



Cutting tools

		TRIAC ST / AT	ELECTRON ST	HOT JET S	GHIBLI / GHIBLI AW	SOLANO AT	WELDING PEN R / S	DIODE PID / S	LABOR S
	117.005 5 spare blades for 117.000	•	•	•	•	•	•	•	•
	117.007 1 universal spacer 0.6 mm for 117.000	•	•	•	•	•	•	•	•

Cable extension

	160.353 Cable cord roller 25 m, 1 x CEE 400 V, 2 x 230 V EU-plug, 5 x 2.5 mm ²	•	•	•	•	•	•	•	•
	161.152 Cable cord roller 25 m, 1 x CEE 400 V, 2 x 230 V CH-plug, 5 x 2.5 mm ²	•	•	•	•	•	•	•	•
	161.207 Cable cord roller 25 m, 1 x CEE 400 V, 2 x 230 V FR, BE, CZ, PL-plug, 5 x 2.5 mm ²	•	•	•	•	•	•	•	•
	164.048 Cable cord roller 45 m, 4 x 230 V EU-plug, 3 x 2.5 mm ²	•	•	•	•	•	•	•	•
	160.015 Cable extension cord 15 m, 5 x 2.5 mm ² CEE 400 V	•	•	•	•	•	•	•	•
	159.239 Cable extension cord 15 m, 3 x 2.5 mm ² with 230 V EU-plug	•	•	•	•	•	•	•	•

Tool rest

	151.068 Tool stand	•							
	107.348 Tool rest	•	•						•
	103.401 Tool rest replaced by 107.348			•					•



¹⁾ POS cardboard box available (please refer to p. 18 / 19)

— TRIAC ST / AT
 — ELECTRON ST
 — HOT JET S
 — GHIBLI / GHIBLI AW
 — SOLANO AT
 — WELDING PEN R / S
 — DIODE PID / S
 — LABORS



Heater tube protection

	148.933 Heater tube protection (only for ELECTRON ST)		•																
-----------------------------------------------------------------------------------	-----------------------------------------------------------------	--	---	--	--	--	--	--	--	--	--	--	--	--	--	--	--	--	--

Heater tube (M14)

	143.332 Heater tube (M14) for screw-on nozzles (only for TRIAC ST till April 2017)		•																
	156.092 Heater tube (M14) for screw-on nozzles (only for TRIAC ST after May 2017)		•																
	144.134 Heater tube (M14) for screw-on nozzles (only for TRIAC AT)		•																

Plastic case

	116.586 Plastic case for TRIAC ST/AT and ELECTRON ST		•	•															
	151.167 Plastic case for SOLANO AT and GHIBLI AW						•	•											

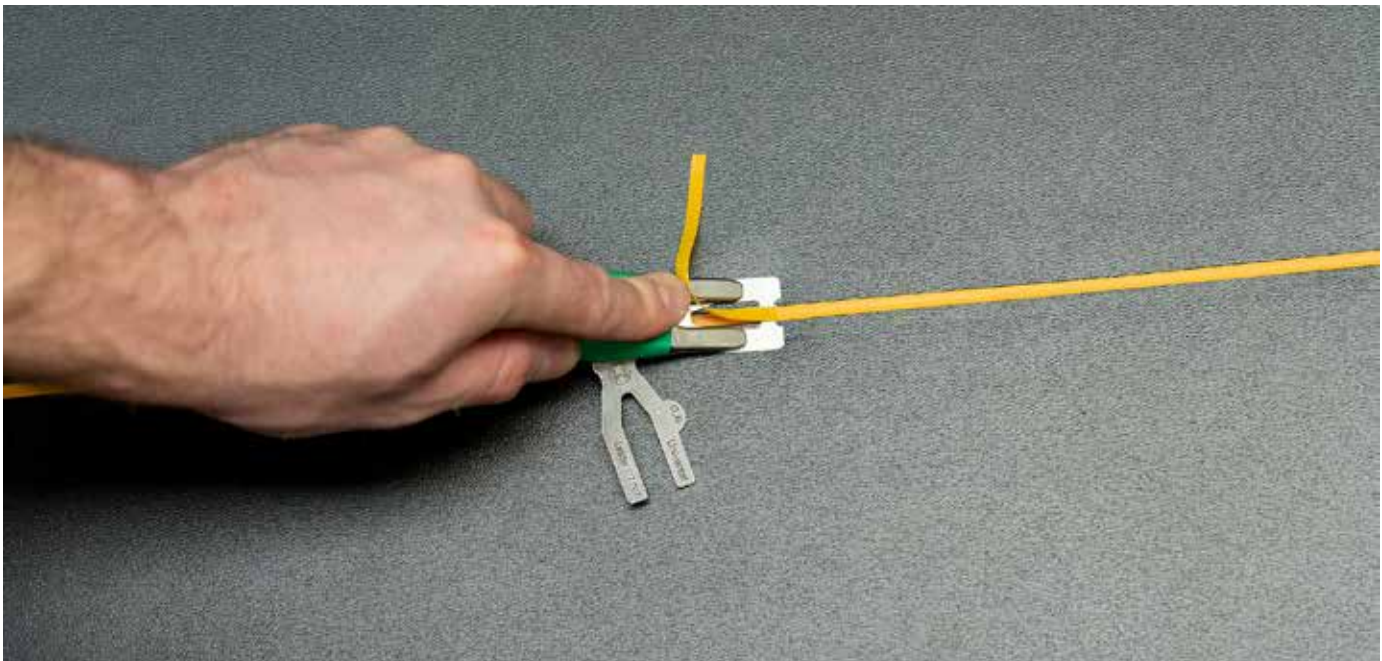

Welding rods



	Profile	Farbe	kg
104.283 Welding rod HDPE	A	■	3
104.294 Welding rod HDPE	A	□	3
104.284 Welding rod HDPE	B	■	5
104.299 Welding rod HDPE	B	□	5
106.650 Welding rod HDPE	C	□	1
104.300 Welding rod LDPE	A	■	3
161.612 Welding rod HDPE	D	■	2
116.918 Welding rod HDPE	D	■	2

Welding accessories PP			
104.287 Welding rod PP	A	■	3
104.301 Welding rod PP	A	■	3
106.642 Welding rod PPs, flame resistant	A	■	3
104.288 Welding rod PP	B	■	5
126.356 Welding rod PP	C	□	2
161.611 Welding rod PP	D	■	2

Welding accessories PVC			
104.296 Welding rod PVC-U	A	□	3
104.278 Welding rod PVC-U	A	■	3
106.641 Welding rod PVC-U	A	■	3
104.280 Welding rod PVC-U	B	■	5
104.279 Welding rod PVC-U	B	■	5
109.925 Welding rod PVC-U	D	■	4
104.302 Welding rod PVC-P (soft)	A	□	3

Welding accessories ABS			
104.295 Welding rod ABS	A	□	3
113.587 Welding rod ABS	A	■	3
107.027 Welding band ABS	C	□	1

Welding accessories div.			
104.297 Welding rod PA	A	■	3
104.298 Welding rod PC	A	□	3
104.313 Welding rod PC / ABS / ALPHA (Honda)	A	■	3
104.308 Welding rod PUR	A	■	3
106.654 Welding band Xenoy	C	■	2
104.304 Welding rod PVDF	A	□	3
104.303 Welding rod POM	A	□	3
112.185 PC/PBTX Xenoy welding rod	A	□	3

Welding accessories	
107.036 Test bundle bodywork welding rods, each consisting of profile A pieces of 37 cm single marked 6x HDPE, 6x PP, 6x PA, 6x PC, 6x ABS, 6x PCABS / ALPHA Honda, 6x PC / PBTP / Xenoy	
107.037 Test bundles standard each consisting pieces of 37 cm single marked 5x PVC-U, 5x PVC-P, 5x PP, 5x ABS, 5x HDPE, 3x PC, 3x PA, 3x POM, 3x LDPE, 3x PC / ABS / ALPHA Honda, 3x PC / PBTP / Xenoy	
107.040 Test bundle welding band each consisting of profile C pieces of 37 cm single marked 9x HDPE 8x 2 mm white, 9x PP, 8x 2 mm natural, 9x ABS, 8x 2 mm white, 9x PC / PBTP / Xenoy grey	
144.095 Welding rod dispenser	

Profile size in mm

Profile A 	Profile B 	Profile C 	Profile D
----------------------	----------------------	----------------------	----------------------

POS Rack



For ordering POS rack,
please contact salssupport@leister.com

POS Sales items

Wide slot nozzle $\varnothing 21.3$ mm		TRIAC ST / AT	ELECTRON ST	HOT JET S	GHIBLI / GHIBLI AW	SOLANO AT	WELDING PEN R / S	DIODE PID / S	LABOR S
	146.721 20 x 2 mm, 30° angled			•					•



Wide slot nozzle $\varnothing 50.0$ mm		TRIAC ST / AT	ELECTRON ST	HOT JET S	GHIBLI / GHIBLI AW	SOLANO AT	WELDING PEN R / S	DIODE PID / S	LABOR S
	157.727 70 x 10 mm, straight, for Bitumen, without clamps			•					













Wide slot nozzle $\varnothing 31.5$ mm		TRIAC ST / AT	ELECTRON ST	HOT JET S	GHIBLI / GHIBLI AW	SOLANO AT	WELDING PEN R / S	DIODE PID / S	LABOR S
	122.836 20 x 2 mm, 15° angled	•							•
	150.126 20 x 2 mm, 60° angled, foil left	•							•
	146.892 20 x 2 mm, 60° angled, foil right	•							•
	150.130 20 x 2 mm, 75° angled	•							•
	137.825 20 x 2 mm, -15° angled, 30° bent	•							•
	121.129 40 x 2 mm, 15° angled	•							•
	150.004 60 x 2 mm, 15° angled, for Bitumen	•							•
	156.207 80 x 2 mm, 15° angled, for Bitumen	•							•





Tubular nozzle $\varnothing 21.3$ mm		TRIAC ST / AT	ELECTRON ST	HOT JET S	GHIBLI / GHIBLI AW	SOLANO AT	WELDING PEN R / S	DIODE PID / S	LABOR S
	153.790 $\varnothing 5$ mm, 41 mm, 15° angled, suitable for speed welding nozzle			•					•

Tubular nozzle $\varnothing 31.5$ mm		TRIAC ST / AT	ELECTRON ST	HOT JET S	GHIBLI / GHIBLI AW	SOLANO AT	WELDING PEN R / S	DIODE PID / S	LABOR S
	152.966 $\varnothing 5$ mm, 37 mm, 15° angled, suitable for speed welding nozzle	•							•





Tubular nozzle $\varnothing 36.5$ mm		TRIAC ST / AT	ELECTRON ST	HOT JET S	GHIBLI / GHIBLI AW	SOLANO AT	WELDING PEN R / S	DIODE PID / S	LABOR S
	152.195 $\varnothing 5$ mm, 41 mm, straight, suitable for speed welding nozzle				•	•			

Wide slot nozzle $\varnothing 36.5$ mm		TRIAC ST / AT	ELECTRON ST	HOT JET S	GHIBLI / GHIBLI AW	SOLANO AT	WELDING PEN R / S	DIODE PID / S	LABOR S
	121.857 20 x 2 mm, 15° angled				•	•			
	109.743 40 x 2 mm, -15° angled				•	•			



Speed welding nozzle $\varnothing 8.0$ mm		TRIAC ST / AT	ELECTRON ST	HOT JET S	GHIBLI / GHIBLI AW	SOLANO AT	WELDING PEN R / S	DIODE PID / S	LABOR S
	155.370 Round $\varnothing 3$ mm, with narrow air slit Profile D 	•	•	•	•	•	•	•	•
NEW 	160.550 Round $\varnothing 3$ mm, with narrow air slit, tip bent Profile D 	•	•	•	•	•	•	•	•
	155.371 Round $\varnothing 4$ mm, with narrow air slit Profile D 	•	•	•	•	•	•	•	•
	154.402 Round $\varnothing 5$ mm Profile D 	•	•	•	•	•	•	•	•
	155.367 Round $\varnothing 5$ mm, with narrow air slit Profile D 	•	•	•	•	•	•	•	•
NEW 	159.848 Round $\varnothing 5$ mm, with narrow air slit, tip bent Profile D 	•	•	•	•	•	•	•	•

Pressure roller		TRIAC ST / AT	ELECTRON ST	HOT JET S	GHIBLI / GHIBLI AW	SOLANO AT	WELDING PENR / S	DIODE PID / S	LABOR S
	155.455 28 mm (PTFE), with ball bearing	•	•	•	•	•	•	•	•
	155.372 28 mm (silicone), with ball bearing	•	•	•	•	•	•	•	•
	156.441 40 mm (silicone), with ball bearing	•	•	•	•	•	•	•	•
	155.456 6 mm (brass), with ball bearing	•	•	•	•	•	•	•	•
	155.457 7 mm (brass), for welding rods Ø4 - 5 mm	•	•	•	•	•	•	•	•

Planer		TRIAC ST / AT	ELECTRON ST	HOT JET S	GHIBLI / GHIBLI AW	SOLANO AT	WELDING PENR / S	DIODE PID / S	LABOR S
	156.203 Chamfer planer for T-joints for sealing sheets	•	•	•	•	•	•	•	•

Various accessories		TRIAC ST / AT	ELECTRON ST	HOT JET S	GHIBLI / GHIBLI AW	SOLANO AT	WELDING PENR / S	DIODE PID / S	LABOR S
	155.461 Seam probe tester for overlap seams	•	•	•	•	•	•	•	•
	137.855 Leister cutter with holster and 4 spare blades	•	•	•	•	•	•	•	•
	155.460 Inside corner tool	•	•	•	•	•	•	•	•
	155.459 Brass brush	•	•	•	•	•	•	•	•

Cutting tools

Cutting tools		TRIAC ST / AT	ELECTRON ST	HOT JET S	GHIBLI / GHIBLI AW	SOLANO AT	WELDING PENR / S	DIODE PID / S	LABOR S
	106.969 Quarter Moon Knife including leather case, 100 mm stainless steel blade	•	•	•	•	•	•	•	•
	109.742 Trimming guide to use with 106.969	•	•	•	•	•	•	•	•



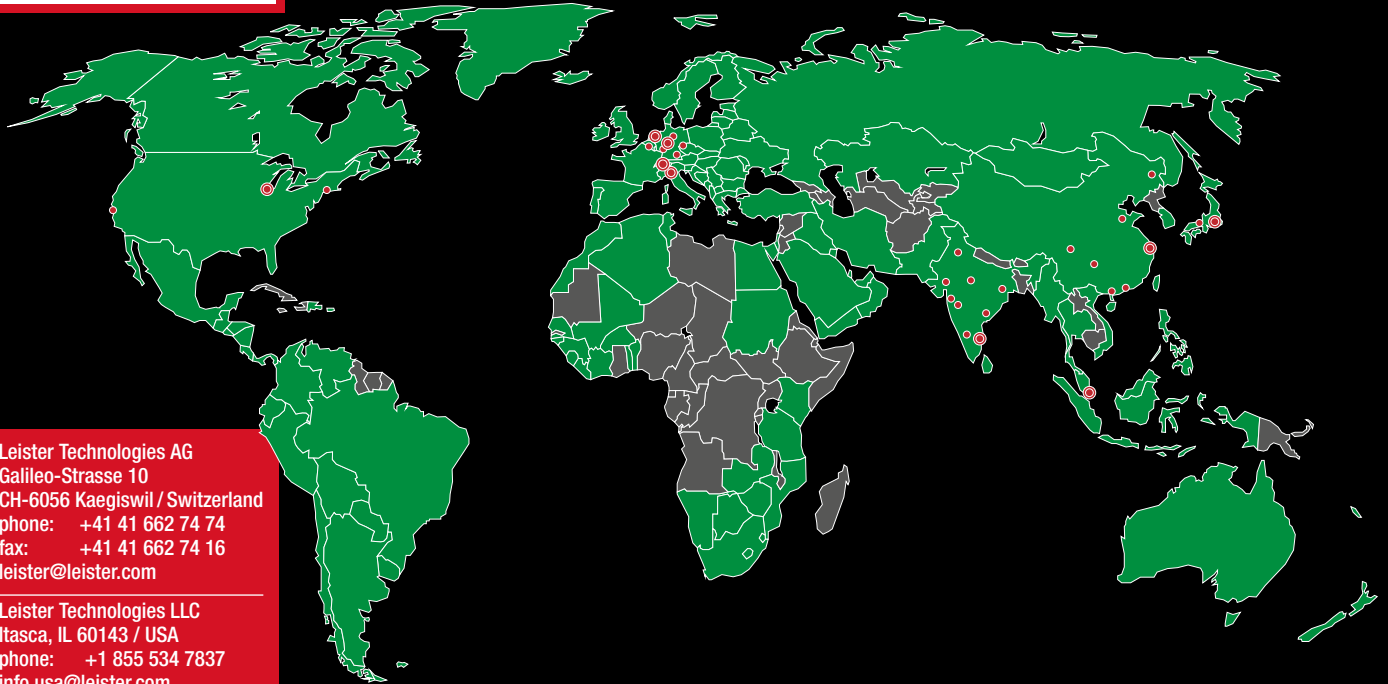

Leister Technologies AG
Galileo-Strasse 10
CH-6056 Kaegiswil / Switzerland
phone: +41 41 662 74 74
fax: +41 41 662 74 16
leister@leister.com

Leister Technologies LLC
Itasca, IL 60143 / USA
phone: +1 855 534 7837
info.usa@leister.com

Leister Technologies Ltd.
Shanghai 201 109 / PRC
phone: +86 21 6442 2398
leister@leister.cn

Leister Technologies KK
Osaka 564-0051 / Japan
phone: +81 6 6310 62 00
sales-japan@leister.com

Leister Technologies Benelux BV
3991 CE Houten / Nederland
phone: +31 (0)30 2199888
info@leister.nl

Leister Technologies Italia s.r.l.
20090 Segrate / Italia
phone: +39 02 2137647
sales@leister.it

Leister Technologies India Pvt
600 041 Chennai / India
phone: +91 44 2454 3436
info@leister.in

Leister Technologies
Deutschland GmbH
D-58093 Hagen / Germany
phone: +49-(0)2331-95940
info.de@leister.com

Our close worldwide network of more than 130 Sales and Service Centres in more than 100 countries.

Europe: Andorra Austria Belgium Cyprus Denmark Finland France Germany Greece Iceland Ireland Italy Luxembourg Malta Monaco Netherlands Norway Portugal Liechtenstein San Marino Spain	Sweden Switzerland Turkey United Kingdom Vatican Albania Armenia Azerbaijan Belarus Bosnia-Herzegovina Bulgaria Croatia Czech Republic Estonia Georgia Hungary Kosovo Latvia Lithuania Macedonia Moldova Montenegro	Poland Romania Russia Serbia Slovakia Slovenia Ukraine Americas: Canada Mexico USA Belize Costa Rica El Salvador Guatemala Honduras Nicaragua Panama Argentina Bolivia Brazil	Chile Colombia Ecuador Peru Venezuela Central Asia: Kazakhstan Kyrgyzstan Tajikistan Turkmenistan Uzbekistan Middle East: Bahrain Iran Iraq Israel Jordan Qatar Saudi Arabia U.A.E	Africa: Algeria Botswana Egypt Ivory Coast Kenya Lesotho Libya Malawi Morocco Mozambique Namibia North Sudan South Africa Swaziland Tunisia Zambia Zimbabwe	Asia Pacific: Bangladesh Greater China India Indonesia Japan Korea Malaysia Mongolia Philippines Singapore Sri Lanka Thailand Vietnam Oceania: Australia New Zealand
-------------------------------------------------------------------------------------------------------------------------------------------------------------------------------------------------------------------------------------------------------------	------------------------------------------------------------------------------------------------------------------------------------------------------------------------------------------------------------------------------------------------------------------------------------	------------------------------------------------------------------------------------------------------------------------------------------------------------------------------------------------------------------------------------------------------	-------------------------------------------------------------------------------------------------------------------------------------------------------------------------------------------------------------------------------------------------------------------	-----------------------------------------------------------------------------------------------------------------------------------------------------------------------------------------------------------------------	----------------------------------------------------------------------------------------------------------------------------------------------------------------------------------------------------------------------------------------

© Copyright by Leister, Switzerland

Your Leister Sales and Service Center: